

**Kemi og Maskinløsninger**

# Indhold

side

## Top Lukkede

Reservedels oversigt	3
Reservedels nummer oversigt	4
Olieskimmer OS-3B	5

## Fler trins maskiner

### C-800 - C-2600

Tekniske data	6
Tekniske data	7
Reservedels oversigt C-800 KD - C800 PD	8
Reservedels Nummer oversigt C-800 KD - C-800 PD	9
Reservedels nummer oversigt C-800 KD - C-800 PD	10
Reservedels oversigt C-1000 KD - C1000 PD	11
Reservedels Nummer oversigt C-1000 KD - C-1000 PD	12
Reservedels nummer oversigt C-1000 KD - C-1000 PD	13
Reservedels oversigt C-1200 KD - C1200 PD	14
Reservedels Nummer oversigt C-1200 KD - C-1200 PD	15
Reservedels nummer oversigt C-1200 KD - C-1200 PD	16
Reservedels oversigt C-1600 KD - C1600 PD	17
Reservedels Nummer oversigt C-1600 KD - C-1600 PD	18
Reservedels nummer oversigt C-1600 KD - C-1600 PD	19
Reservedels oversigt C-2000 KD - C2000 PD	20
Reservedels Nummer oversigt C-2000 KD - C-2000 PD	21
Reservedels nummer oversigt C-2000 KD - C-2000 PD	22
Reservedels oversigt C-2600 KD - C2600 PD	23
Reservedels Nummer oversigt C-2600 KD - C-2600 PD	24
Reservedels nummer oversigt C-2600 KD - C-2600 PD	25
Olieskimmer OS-3S	26
Vandfordeler	27



# 10. SPARE PART LISTS

## 10.1 SPARE PART LISTS TL-650SS, TL-900SS, TL-1150SS

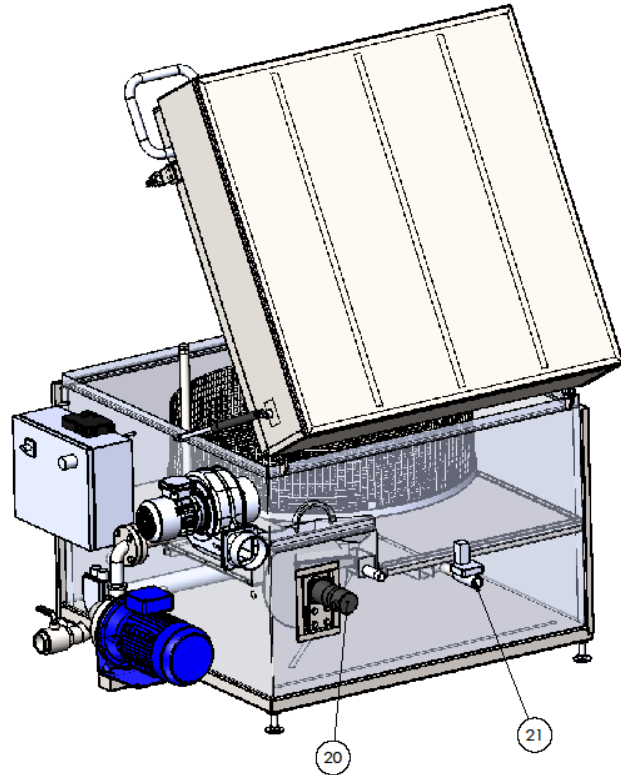
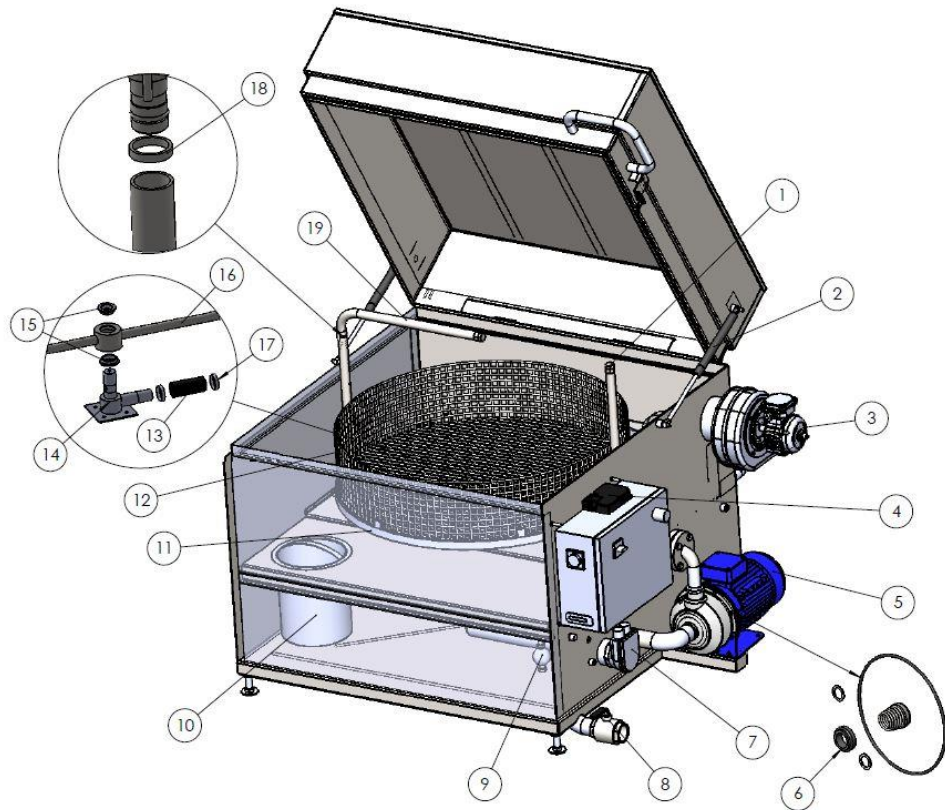

Pos.	Name	Qty	Order no.		
			TL-650SS	TL-900SS	TL-1150SS
1	Cleaning plug	2	PC102	PC102	PC102
2	Gas spring	2	PJ052	PJ052	PJ056
2.1	Locking tube	1	PJ057	PJ057	-
6	Shaft seal set	1	VPE027	VPE027	VPE027
8	Ball valve	1	PP026	PP026	PP026
10	Filter i	1	H250	H250	H250
11	Load table - stainless	1	2550740	2558211	1028177
12	Load basket - stainless	1	LB-065S	LB-090S	-
12	Load grating - stainless	1	-	-	LG-12S
13	Rubber hose	0,12	PK160	PK160	PK160
14	Water chamber shaft, standard	1	2313340	2313340	2313340
14	Water chamber shaft, stainless	1	2313341	2313341	2313341
15	Water chamber bushing, black nitrated	2	4333020	4333020	4333020
15	Water chamber bushing, brass standard	2	4333022	4333022	4333022
16	Spray pipe	1	1027385	1027388	1028183
17	Hose clip	2	PD045	PD045	PD045
18	Nylon ring	1	2334580-5	2334580-5	2334580-5
19	Upper spray pipe	1	2308641	2308641	1028184
20	Oil skimmer	1	OS-3B	OS-3B	OS-3B
	Adjustable leg	4	4257270	4257270	4257270
	<b>ELECTRIC PARTS</b>				
	Thermostat	1	PI612	PI612	PI612
	Temperature probe	1	PI613	PI613	PI613
21	Solenoid valve (automatic refill)	1	CPI139	CPI139	CPI139
	Cleaning time relay	1	PI027	PI027	PI027
	Steam extractor timer relay	1	PI550	PI550	PI550
3	Steam extractor	1	DF-1	DF-1	DF-1
	Adapter for steam extractor	1	DFO-110	DFO-110	DFO-110
	Gasket for steam extractor	1	PK008	PK008	PK008
4	Electrical lock	1	PI635	PI635	PI635
5	Pump	1	PI092	PI092	PI092
7	Heating element 6 kW 230/400/415V	1	PI241	-	-
7	Heating element 6 kW 500V	1	PI243	-	-
7	Heating element 9 kW 230/400/415V	1	-	PI063	PI063
7	Heating element 9 kW 500V	1	-	PI065	PI065
9	Fluid level guard, standard equipment	1	PI030	PI030	PI030
9	Fluid level guard, automatic water refill	1	PI030	PI030	PI030

**Please state the serial number of the cleaning machine when ordering spare parts.**

It is also possible to order spare parts not mentioned in the above list. Please contact the supplier or manufacturer for further information. Please state the serial number of the cleaning machine when ordering spare parts.



## 10.2

## OIL SKIMMER OS-3B

Pos.	Name	Qty	Order no.
1	Scraper	1	2420110A
2	Disc	1	4350990
3	Shaft	1	1028492
4	Shaft seal	1	PK169
5	Mounting bracket	1	1001821
6	Gear motor	1	PI073

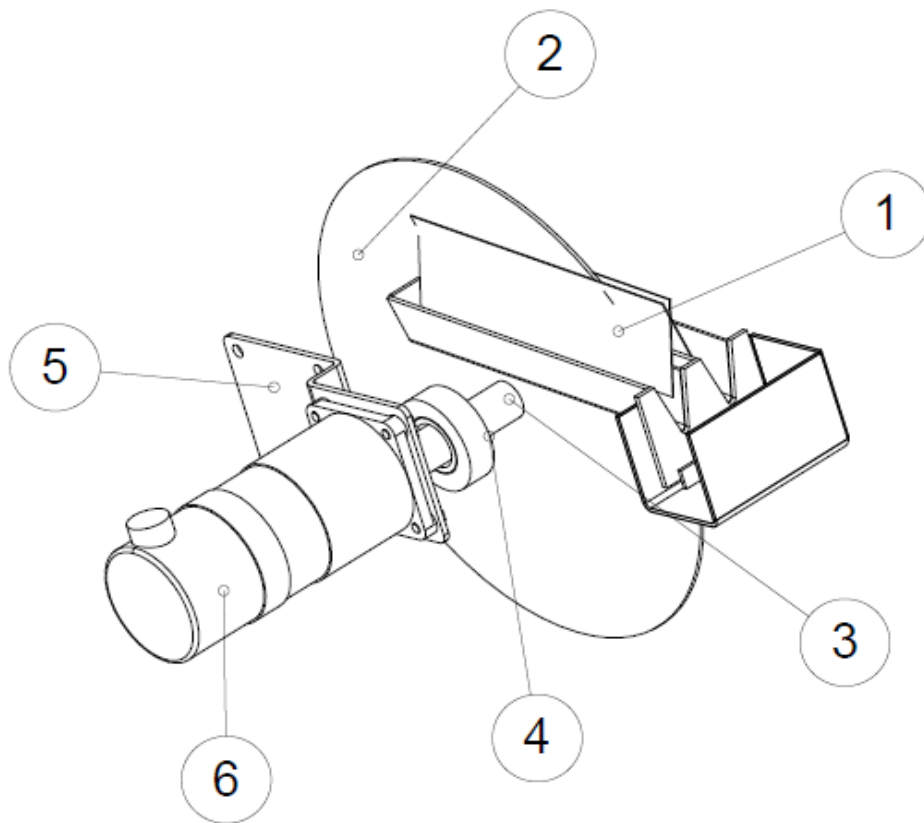



## 1. TECHNICAL DATA

<b>Model</b>		<b>C-800</b>	<b>C-1000</b>	<b>C-1000H</b>	
Maximum load dimensions					
- length, width	mm	800/700	1050/900	1050/900	
- height	mm	550	800	1200	
- diameter	mm	700	900	900	
Maximum load	kg	500	500	500	
Connection power	kW	13	17	17	
Heating capacity	kW	9	12	12	
Tank volume	litres	350	650	650	
Pump					
- capacity	l/min	320	370	370	
- pressure	kPa	400	370	320	
- motor	kW	4.0	4.0	4.0	
Weight	kg	400	650	750	
Steam extractor					
- type		DF-250S	DF-250S	DF-250S	
- capacity	m <sup>3</sup> /h	1200	1200	1200	
- motor	kW	0.25	0.25	0.25	
<b>Model</b>		<b>C-1200</b>	<b>C-1200H</b>	<b>C-1600</b>	<b>C-1600H</b>
Maximum load dimensions					
- length, width	mm	1200/1100	1200/1100	1600/1400	1600/1400
- height	mm	700	1200	800	1200
- diameter	mm	1100	1100	1400	1400
Maximum load	kg	700	700	700	700
Connection power	kW	19	19	25	25
Heating capacity	kW	18	18	24	24
Tank volume	litres	800	800	1300	1300
Pump					
- capacity	l/min	400	450	460	600
- pressure	kPa	350	310	400	450
- motor	kW	4.0	4.0	5.5	7.5
Weight	kg	750	850	1000	1100



<b>Model</b>		<b>C-1200</b>	<b>C-1200H</b>	<b>C-1600</b>	<b>C-1600H</b>
Steam extractor					
- type		DF-250S	DF-250S	DF-250S	DF-250S
- capacity	m <sup>3</sup> /h	1200	1200	1200	1200
- motor	kW	0.25	0.25	0.25	0.25

<b>Model</b>		<b>C-2000</b>	<b>C-2000H</b>	<b>C-2600</b>	<b>C-2600H</b>
Maximum load dimensions					
- length, width	mm	2000/1800	2000/1800	2600/2300	2600/2300
- height	mm	800	1200	800	1200
- diameter	mm	1800	1800	2300	2300
Maximum load	kg	1000	1000	2500	2500
Connection power	kW	37	37	49	49
Heating capacity	kW	36	36	48	48
Tank volume	litres	1900	1900	3100	3100
Pump					
- capacity	l/min	600	660	660	720
- pressure	kPa	450	420	530	520
- motor	kW	7.5	7.5	11.0	11.0
Weight	kg	1300	1500	2000	2200
Steam extractor					
- type		DF-250S	DF-250S	DF-3	DF-3
- capacity	m <sup>3</sup> /h	1200	1200	2000	2000
- motor	kW	0.25	0.25	0.55	0.55

## C-800 KD

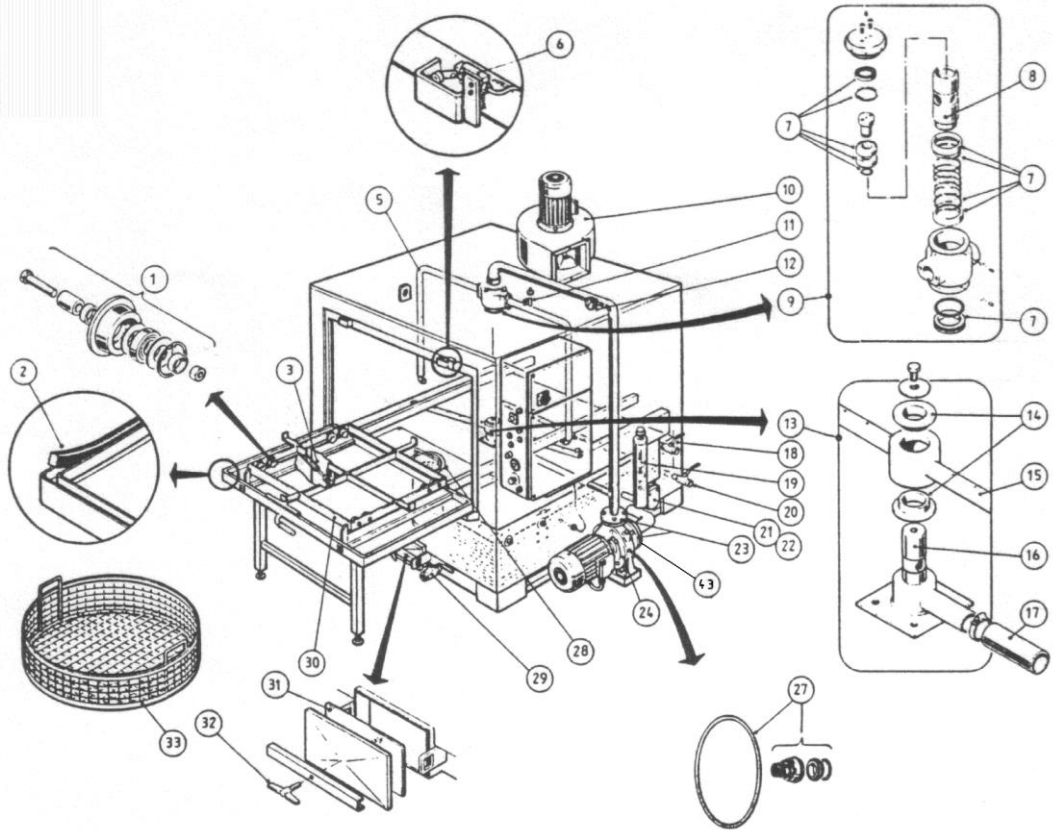

## C-800 PD

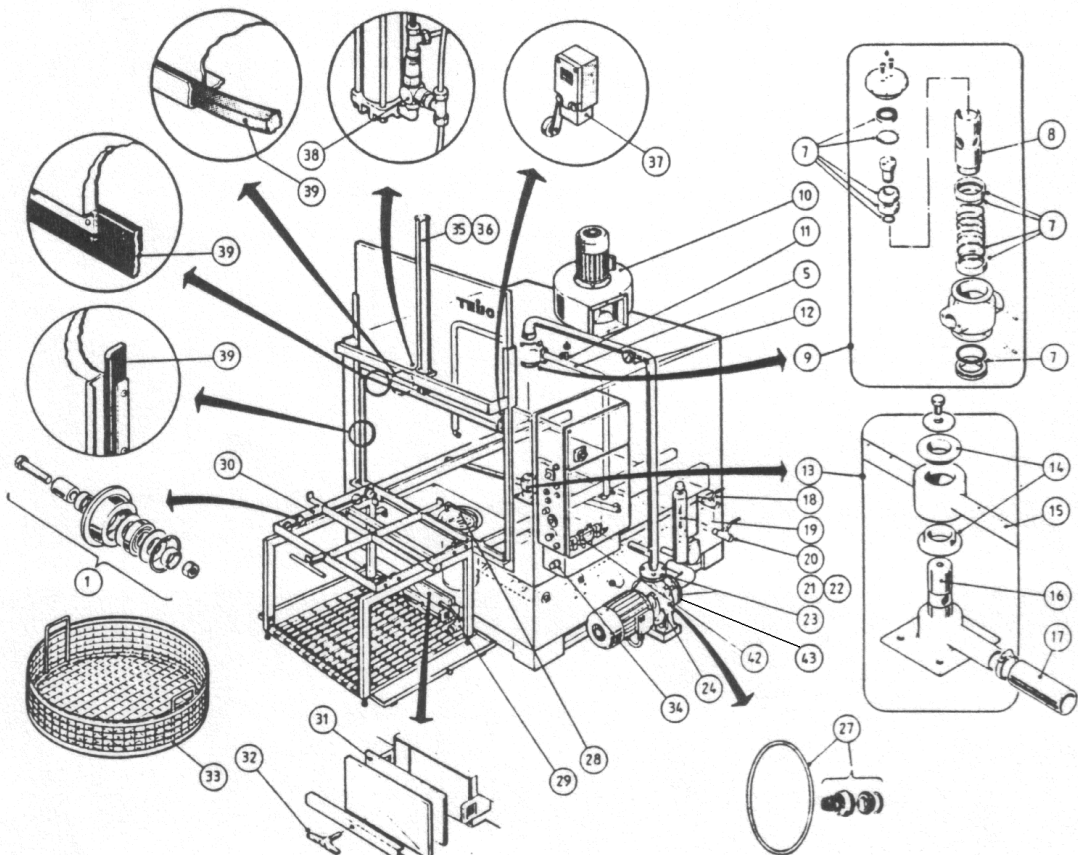



1	1024122	Wheel, load carriage (complete)	8
2	PK147	Door gasket	3 m
3	PJ 052	Gas cylinder	1
5	4441860/70	Upper spray pipe (C-800) AISI 304	1+1
5.1	3561440	Upper spray pipe (C-800H) AISI 304	1
6	PI 316	Limit switch, KD-door	1
7	V169819	Seal set, upper water chamber	1
8	3389340	Shaft, upper water chamber	1
9	2353530	Upper water chamber	1
10	DF-250S	Steam extractor	1
11	PI 251	Rotation indicator	1
12	PP 118	Pressure gauge	1
13	See pos. 14, 15, 16		
14	4333020	Bearing bushings (2 pcs)	1
15	4444950	Lower spray pipe AISI 304	1
16	4333030	Shaft, lower water chamber	1
17	PK 160	Rubber hose	1
18	PP 071	Ball valve (manual water refill)	1
	CPI 139	Solenoid valve (automatic water refill)	1
	PP 021	Mud filter (automatic water refill)	1
19	PI 389	Level guard (manual water refill)	1
	PI 382	Level guard (automatic water refill)	1
20	PP 071	Ball valve (tank cleaning)	1
21	PI 063	Heating element 9 kW, 230/400/415 V	1
	PI 065	Heating element 9 kW, 500 V	1
22	PI 066	Cover	1
23	PK 189	Flange seal	1
24	PI 1540	Pump	1
27	VPE0410	Shaft seal set, pump incl. o-ring	1
28	H-400	Filter basket	1
29	PP 072	Drainage valve	1
30	LC-081	Load carriage St 12	1
	LC-081G	Load carriage St 12, galvanised	1
	LC-081S	Load carriage AISI 304	1
31	PK 006	Seal, cleaning hatch	1
33	LB-082	Load grating St 12	1
	LB-082G	Load grating St 12, galvanised	1
	LB-082S	Load grating AISI 304	1
34	PT 403	Pressure regulator (air pressure)	1
35	PT 452	Pressure-air cylinder	1

37	PI316	Limit switch	1
38	PT 400	Hose break valve	2
39	PK162	Seal set, PD-door	4 m
42	PT 438	Pressure air valve, PD-door	1
43	PT 308	Stop valve	1

### Electrical parts / electrical control box

PI 027	Cleaning time relay	1
PI 550	Time relay, steam extractor, drainage time	2
PI 011	Contact relay	
	- C-800 KD	1
	- C-800 PD	2
PI 152	Weekly timer	1
PI 612	Thermostat/thermometer	1
PI 613	Temperature probe	1

Please state the serial number of the cleaning machine when ordering spare parts.



## 10.2 C-1000 KD, C-1000 PD

### C-1000 KD

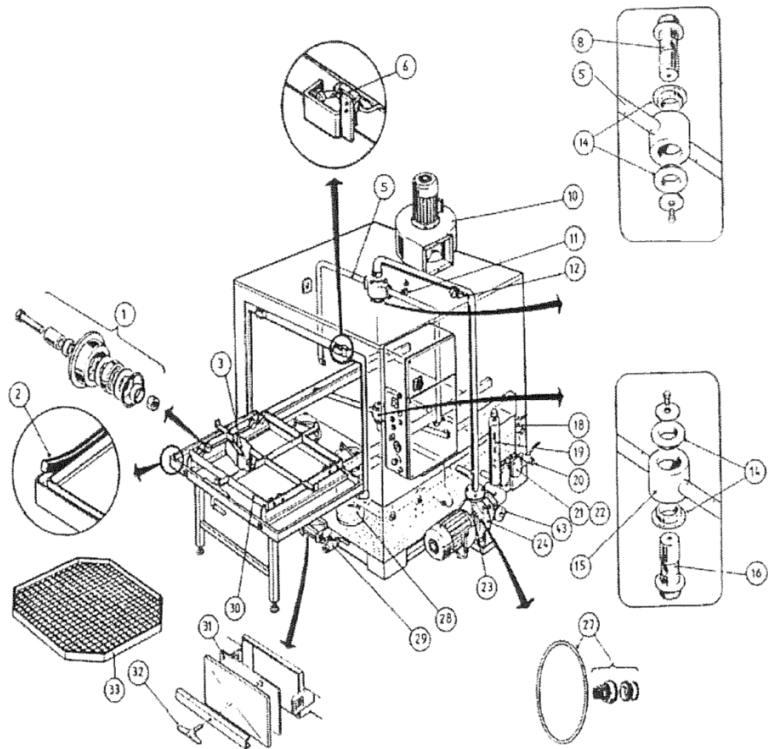

### C-1000 PD

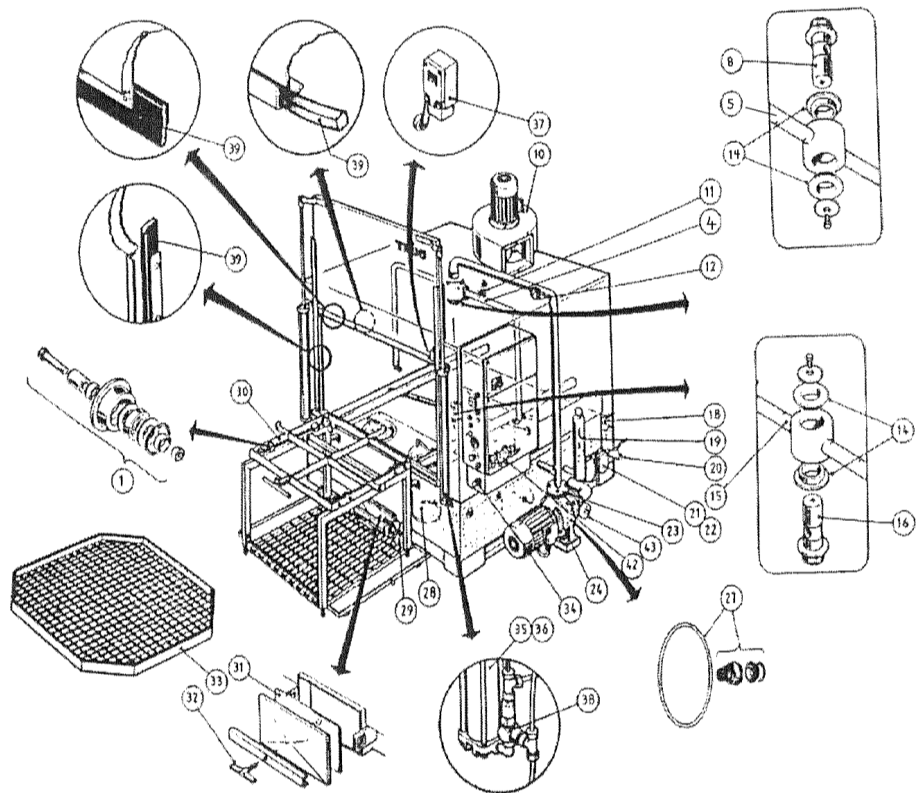

## Spare parts list C-1000 KD, C-1000 PD

Pos.	Code no.	Description	Quantity
1	1024122	Wheel, load carriage (complete)	8
2	PK147	Door gasket	4 m
3	PJ 056	Gas cylinder	1
5	1012522	Upper spray pipe (C-1000) AISI 304	1
5.1	3571550	Upper spray pipe (C-1000H) AISI 304	1
6	PI 316	Limit switch, KD-door	1
8	4315720	Shaft, upper water chamber	1
10	DF-250S	Steam extractor	1
11	PI 251	Rotation indicator	1
12	PP 118	Pressure gauge	1
14	4333020	Bearing bushings (2 pcs)	2
15	3482730	Lower spray pipe AISI 304	1
16	4315720	Shaft, lower water chamber	1
18	PP 071	Ball valve (manual water refill)	1
	CPI 139	Solenoid valve (automatic water refill)	1
	PP 021	Mud filter (automatic water refill)	1
19	PI 389	Level guard (manual water refill)	1
	PI 382	Level guard (automatic water refill)	1
20	PP 071	Ball valve (tank cleaning)	1
21	PI 238	Heating element 12 kW, 230/400/415 V	1
22	PI 066	Cover	1
23	PK 189	Flange seal	1
24	PI 1540	Pump	1
27	VPE0410	Shaft seal set, pump, incl. o-ring	1
28	H-400	Filter basket	2
29	PP 072	Drainage valve	1
30	LC-101	Load carriage St 12	1
	LC-101G	Load carriage St 12, galvanised	1
	LC-101S	Load carriage AISI 304	1
31	PK 006	Seal, cleaning hatch	1
33	LG-10	Load grating St 12, galvanised	1
	LG-10S	Load grating AISI 304	1
34	PT 403	Pressure regulator (air pressure)	1
35	PT 454	Pressure-air cylinder (C-1000)	2
35.1	PT 456	Pressure-air cylinder (C-1000H)	2





## Spare parts list C-1000 KD, C-1000 PD

<b>Pos.</b>	<b>Code no.</b>	<b>Description</b>	<b>Quantity</b>
37	PI 316	Limit switch, PD-door	1
38	PT 400	Hose break valve	2
39	PK185	Seal set, PD-door, C-1000	4,5 m
	PK185	Seal set, PD-door C-1000H	5,5 m
42	PT 438	Pressure air valve, PD-door	1
43	PT 308	Stop valve	1

## Electrical parts / electrical control box

PI 027	Cleaning time relay	1
PI 550	Time relay, steam extractor, drainage time	2
PI 011	Contactory relay	
	- C-1000 KD	1
	- C-1000 PD	2
PI 152	Weekly timer	1
PI 612	Thermostat/thermometer	1
PI 613	Temperature probe	1

Please state the serial number of the cleaning machine when ordering spare parts.

### 10.3 C-1200 KD, C-1200 PD

#### C-1200 KD

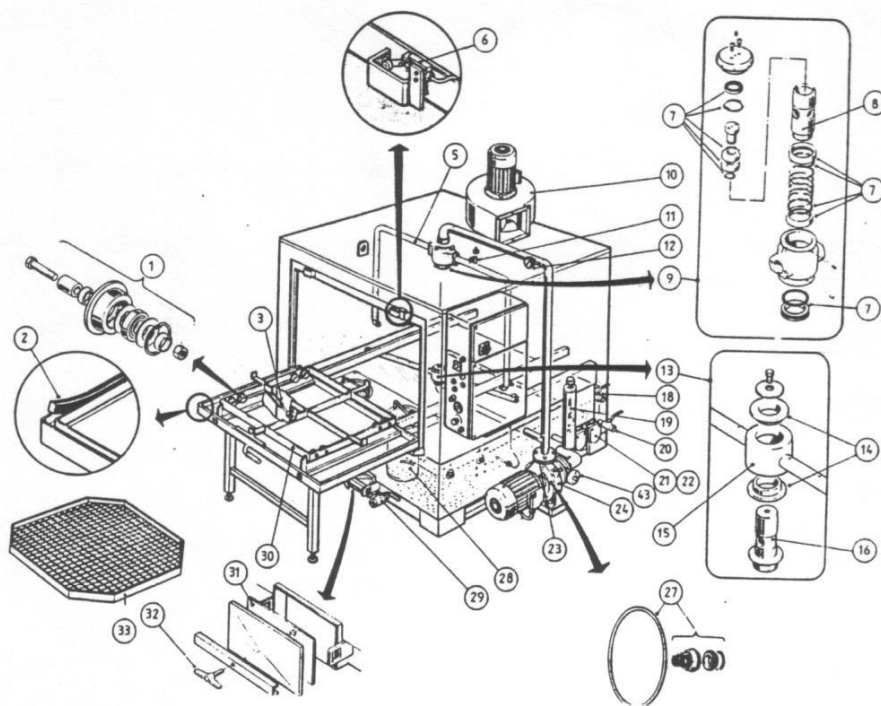

#### C-1200 PD

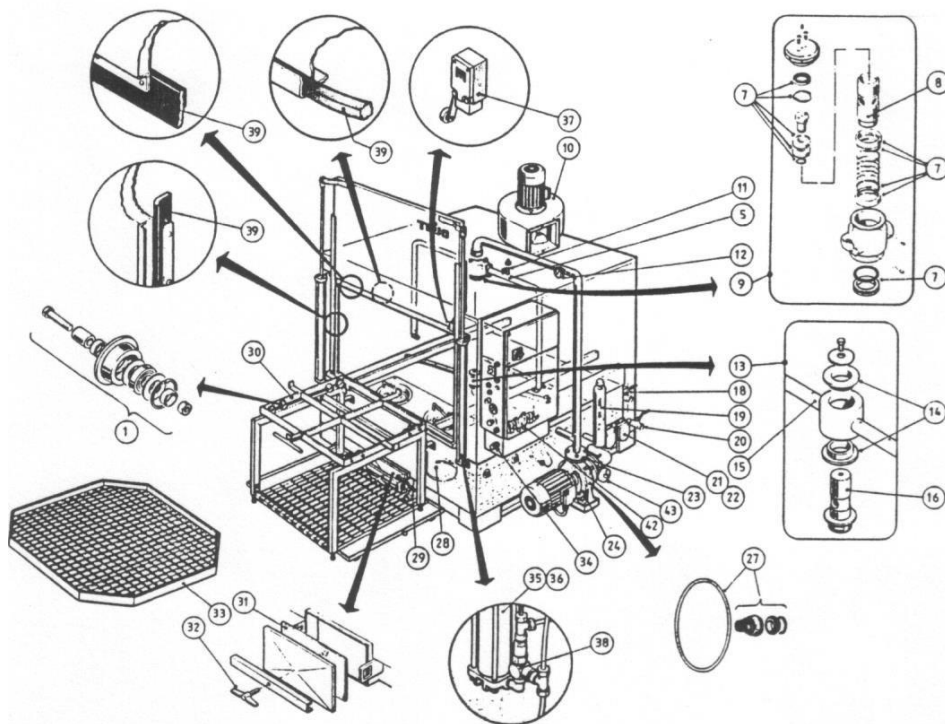

## Spare parts list C-1200 KD, C-1200 PD

Pos.	Code no.	Description	Quantity
1	1024122	Wheel, load carriage (complete)	8
2	PK147	Door gasket	4,3 m
3	PJ 056	Gas cylinder	1
5	3421700/-10	Upper spray pipe (C-1200) AISI 304	1 + 1
5.1	3425200/-10	Upper spray pipe (C-1200H) AISI 304	1 + 1
6	PI 316	Limit switch, KD-door	1
7	V169819	Seal set, upper water chamber	1
8	3389340	Shaft, upper water chamber	1
9	2353530	Upper water chamber	1
10	DF-250S	Steam extractor	1
11	PI 251	Rotation indicator	1
12	PP 118	Pressure gauge	1
13	4315801	Lower water chamber	1
14	4333020	Bearing bushings (2 pcs)	1
15	3460610	Lower spray pipe AISI 304	1
16	4315720	Shaft, lower water chamber	1
18	PP 071	Ball valve (manual water refill)	1
	CPI 139	Solenoid valve (automatic water refill)	1
	PP 021	Mud filter (automatic water refill)	1
19	PI 389	Level guard (manual water refill)	1
	PI 382	Level guard (automatic water refill)	1
20	PP 071	Ball valve (tank cleaning)	1
21	PI 063	Heating element 9 kW, 230/400/415 V	2
	PI 065	Heating element 9 kW, 500 V	2
22	PI 066	Cover	2
23	PK 167	Flange seal	1
24	PI 1540	Pump	1
	PI 1230	Pump C-1200HSS	1
27	VPE 0410	Shaft seal set, pump, incl. o-ring	1
28	H-250	Filter basket	1
28.1	H-400	Filter basket	1
29	PP 072	Drainage valve	1
30	LC-121	Load carriage St 12	1
	LC-121G	Load carriage St 12, galvanised	1
	LC-121S	Load carriage AISI 304	1
31	PK 004	Seal, cleaning hatch	1
32	PC 009	Hexagon screw	1
33	LG-12	Load grating St 12, galvanised	1
	LG-12S	Load grating AISI 304	1

## Spare parts list C-1200 KD, C-1200 PD

<b>Pos.</b>	<b>Code no.</b>	<b>Description</b>	<b>Quantity</b>
34	PT 403	Pressure regulator (air pressure)	1
35	PT 453	Pressure-air cylinder (C-1200)	2
35.1	PT 456	Pressure-air cylinder (C-1200H)	2
37	PI 316	Limit switch, PD-door	1
38	PT 400	Hose break valve	2
39	PK185	Seal set, PD-door, C-1200	4,5 m
	PK185	Seal set, PD-door, C-1200H	5,5 m
42	PT 438	Pressure air valve, PD-door	1
43	PT 308	Stop valve	1

## Electrical parts / electrical control box

PI 027	Cleaning time relay	1
PI 550	Time relay, steam extractor, drainage time	2
PI 011	Contact relay	
	- C-1200 KD	1
	- C-1200 PD	2
PI 152	Weekly timer	1
PI 612	Thermostat/thermometer	1
PI 613	Temperature probe	1

Please state the serial number of the cleaning machine when ordering spare parts.





# 10.4 C-1600 KD, C-1600 PD

## C-1600 KD

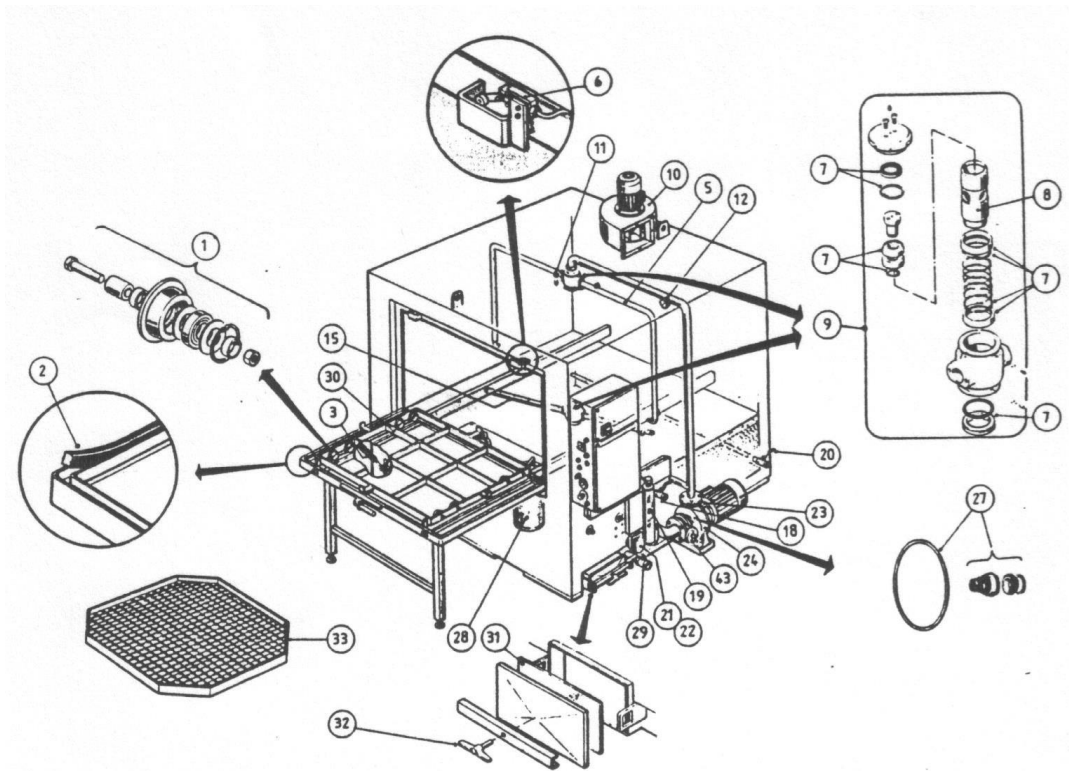

## C-1600 PD

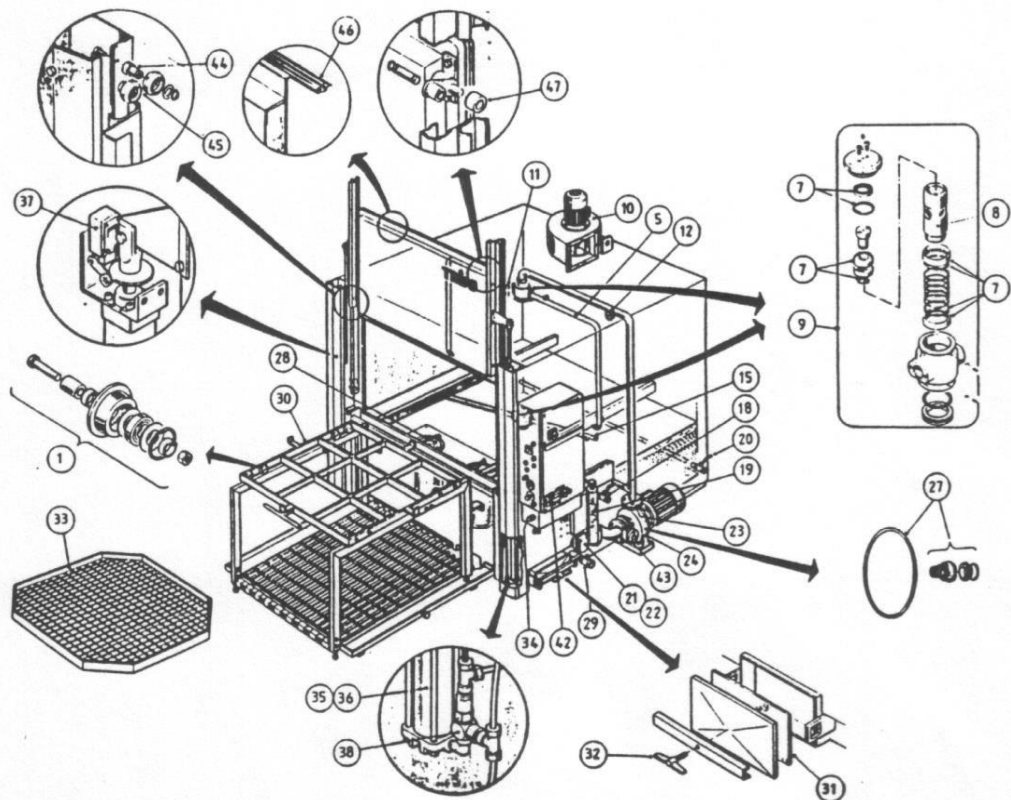

## Spare parts list C-1600 KD, C-1600 PD

Pos.	Code no.	Description	Quantity
1	1024122	Wheel, load carriage (complete)	8
2	KL 161	Door gasket	1
3	PJ 056	Gas cylinder	1
5	3482710/-20	Upper spray pipe (C-1600) AISI 304	1 + 1
5.1	3535760/-70	Upper spray pipe (C-1600H) AISI 304	1 + 1
6	PI 316	Limit switch, KD-door	1
7	V169819	Seal set, upper water chamber	1
8	3389340	Shaft, upper water chamber	1
9	2353530	Upper water chamber	1
10	DF-250S	Steam extractor	1
11	PI 251	Rotation indicator	1
12	PP 118	Pressure gauge	1
15	4341300/-01	Lower spray pipe AISI 304	1 + 1
18	PP 071	Ball valve (manual water refill)	1
	CPI 139	Solenoid valve (automatic water refill)	1
	PP 021	Mud filter (automatic water refill)	1
19	PI 389	Level guard (manual water refill)	1
	PI 382	Level guard (automatic water refill)	1
20	PP 071	Ball valve (tank cleaning)	1
21	PI 238	Heating element 12 kW, 230/400/415 V	2
	PI 240	Heating element 12 kW, 500 V	2
22	PI 066	Cover	2
23	PK 167	Flange seal (C-1600)	1
23.1	PK 163	Flange seal (C-1600H)	1
24	PI 1230	Pump (C-1600)	1
24.1	PI 1240	Pump (C-1600H)	1
27	VPE0410	Shaft seal set, pump	1
28	H-400	Filter basket	1
29	PP 072	Drainage valve	1
30	LC-161	Load carriage St 12	1
	LC-161G	Load carriage St 12, galvanised	1
	LC-161S	Load carriage AISI 304	1
31	PK 006	Seal, cleaning hatch	1
33	LG-16	Load grating St 12, galvanised	1
	LG-16S	Load grating AISI 304	1
35	PT 454	Pressure-air cylinder (C-1600)	2
35.1	PT 456	Pressure-air cylinder (C-1600H)	2
37	PI 316	Limit switch, PD-door	1
38	PT 400	Hose break valve	2
42	PT 438	Pressure air valve, PD-door	1
43	PT 308	Stop valve (C-1600)	1
43.1	PT 308	Stop valve (C-1600H)	1



## Spare parts list C-1600 KD, C-1600 PD

<b>Pos.</b>	<b>Code no.</b>	<b>Description</b>	<b>Quantity</b>
44	4397950	Shaft (C-1600)	8
44.1	4397950	Shaft (C-1600H)	12
45	4397960	Roll, door (C-1600)	8
45.1	4397960	Roll, door (C-1600H)	12
46	PK185	Door gasket (C-1600)	5 m
46.1	PK185	Door gasket (C-1600H)	5,8 m
47	4357470	Guide roll	2

## Electrical parts / electrical control box

PI 027	Cleaning time relay	1
PI 550	Time relay, steam extractor, drainage time	2
PI 011	Contactory relay	
	- C-1600 KD	1
	- C-1600 PD	2
PI 152	Weekly timer	1
PI 612	Thermostat/thermometer	1
PI 613	Temperature probe	1

Please state the serial number of the cleaning machine when ordering spare parts.



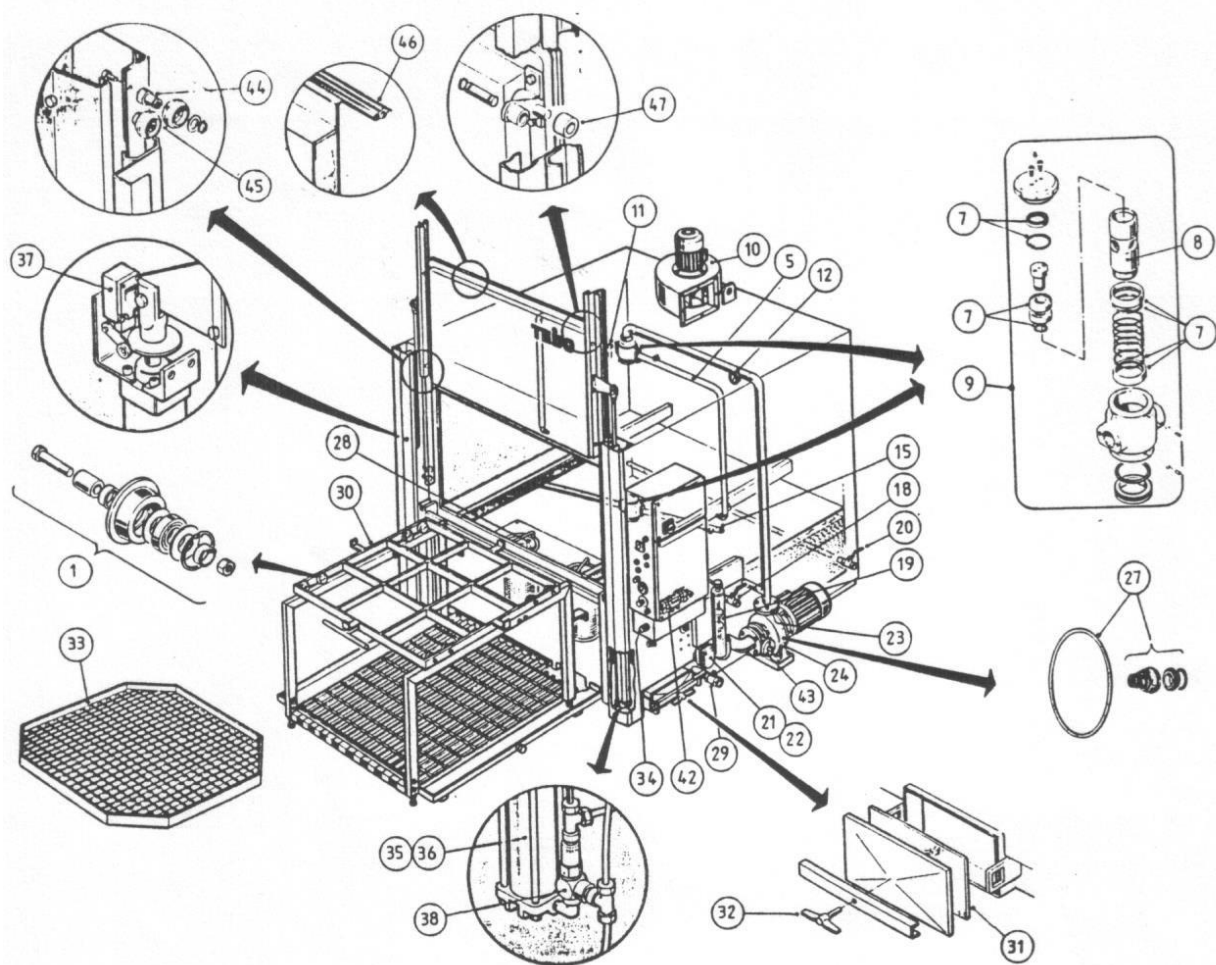



## Spare parts list C-2000 PD

Pos.	Code no.	Description	Quantity
1	1024122	Wheel, load carriage (complete)	8
5	3490865/-75	Upper spray pipe (C-2000) AISI 304	1 + 1
5.1	3554450/-60	Upper spray pipe (C-2000H) AISI 304	1 + 1
7	V169819	Seal set, upper water chamber	1
8	3389340	Shaft, upper water chamber	1
9	2353530	Upper water chamber	1
10	DF-250S	Steam extractor	1
11	PI 251	Rotation indicator	1
12	PP 118	Pressure gauge	1
15	4529890/-900	Lower spray pipe AISI 304	1 + 1
18	PP 071	Ball valve (manual water refill)	1
	CPI 139	Solenoid valve (automatic water refill)	1
	PP 021	Mud filter (automatic water refill)	1
19	PI 389	Level guard (manual water refill)	1
	PI 382	Level guard (automatic water refill)	1
21	PI 238	Heating element 12 kW, 230/400/415 V	3
22	PI 066	Cover	3
23	PK 189	Flange seal	1
24	PI 1240	Pump	1
27	VPE0410	Shaft seal set, pump	1
28	H-400	Filter basket	1
29	PP 072	Drainage valve	1
30	LC-201	Load carriage St 12	1
	LC-201G	Load carriage St 12, galvanised	1
	LC-201S	Load carriage AISI 304	1
31	PK 006	Seal, cleaning hatch	1
33	LG-20	Load grating St 12, galvanised	1
	LG-20S	Load grating AISI 304	1
34	PT 403	Pressure regulator (air pressure)	1
35	PT 454	Pressure-air cylinder (C-2000)	2
35.1	PT 456	Pressure-air cylinder (C-2000H)	2
37	PI 316	Limit switch, PD-door	1
38	PT 400	Hose break valve	2
42	PT 438	Pressure air valve, PD-door	1
43	PT 308	Stop valve	1
44	4397950	Shaft (C-2000)	8
44.1	4397950	Shaft (C-2000H)	12
45	4397960	Roll, door (C-2000)	8
45.1	4397960	Roll, door (C-2000H)	12

## Spare parts list C-2000 PD

<b>Pos.</b>	<b>Code no.</b>	<b>Description</b>	<b>Quantity</b>
46	KP 201	Door gasket (C-2000)	1
46.1	KP 202	Door gasket (C-2000H)	1
47	4357470	Guide roll	2

### Electrical parts / electrical control box

PI 027	Cleaning time relay	1
PI 550	Time relay, steam extractor, drainage time	2
PI 011	Contact relay	2
PI 152	Weekly timer	1
PI 612	Thermostat/thermometer	1
PI 613	Temperature probe	1

Please state the serial number of the cleaning machine when ordering spare parts.



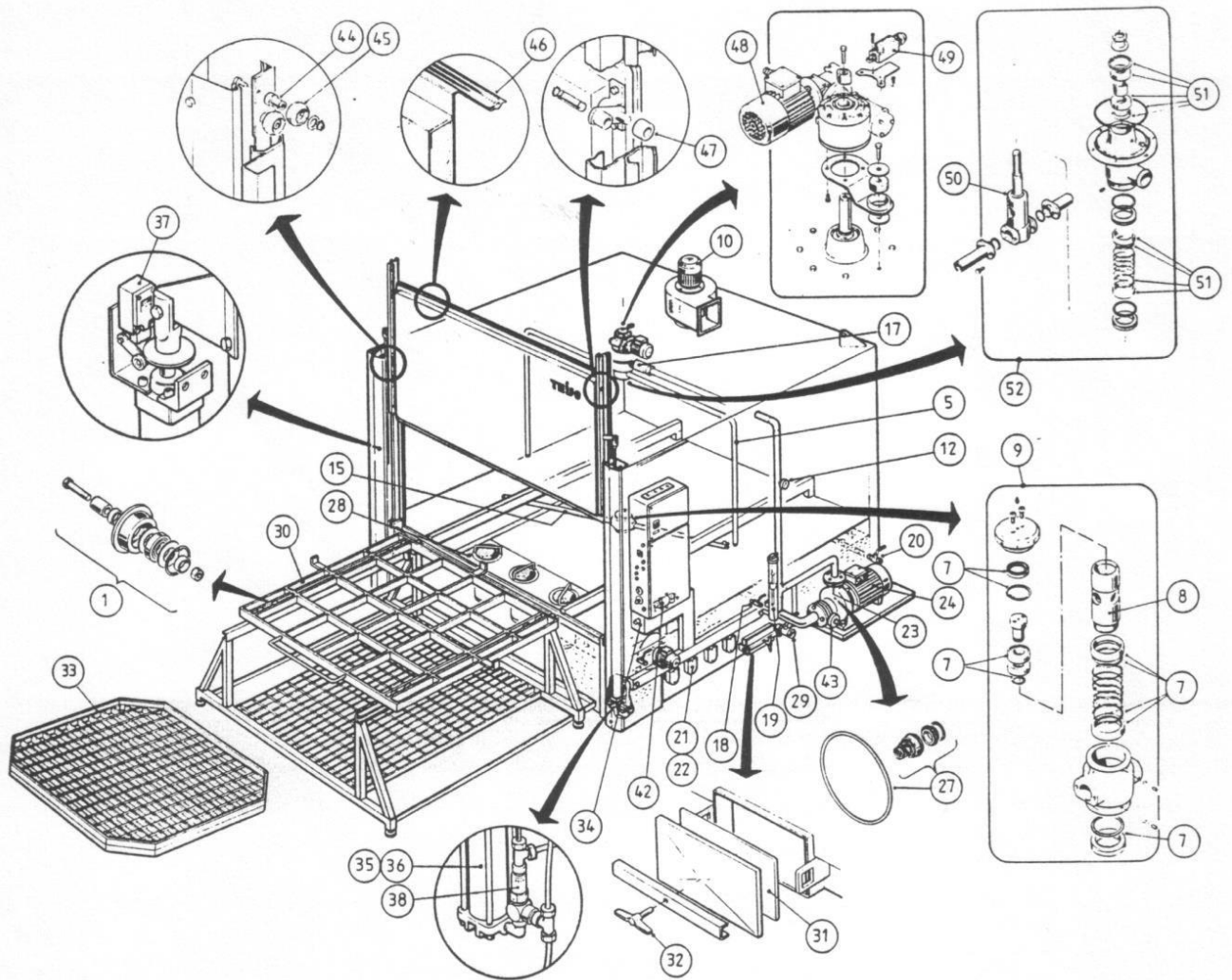

## Spare parts list C-2600 PD

Pos.	Code no.	Description	Quantity
1	1024920	Wheel, load carriage (complete)	12
5	3482270/-71	Upper spray pipe (C-2600) AISI 304	1 + 1
5.1	3482275/-76	Upper spray pipe (C-2600H) AISI 304	1 + 1
7	V169819	Seal set, upper water chamber	1
8	3389340	Shaft, upper water chamber	1
9	2353530	Upper water chamber	1
10	DF-3	Steam extractor	1
12	PP 118	Pressure gauge	1
15	3536080	Lower spray pipe AISI 304	1
18	PP 071	Ball valve (manual water refill)	1
	CPI 139	Solenoid valve (automatic water refill)	1
	PP 021	Mud filter (automatic water refill)	1
19	PI 389	Level guard (manual water refill)	1
	PI 382	Level guard (automatic water refill)	1
20	PP 071	Ball valve (tank cleaning)	1
21	PI 238	Heating element 12 kW, 230/400/415 V	4
21.1	PI 240	Heating element 12 kW, 500 V	4
22	PI 066	Cover	4
23	PK 189	Flange seal	1
24	PI 1250	Pump	1
27	VPE0410	Shaft seal set, pump	1
28	H-400	Filter basket	1
29	PP 072	Drainage valve	1
30	LC-261	Load carriage St 12	1
	LC-261G	Load carriage St 12, galvanised	1
	LC-261S	Load carriage AISI 304	1
31	PK 006	Seal, cleaning hatch	1
33	LG-26	Load grating St 12, galvanised	1
	LG-26S	Load grating AISI 304	1
35	PT 454	Pressure-air cylinder (C-2600)	2
35.1	PT 456	Pressure-air cylinder (C-2600H)	2
37	PI 316	Limit switch, PD-door	1
38	PT 400	Hose break valve	2
42	PT 438	Pressure air valve, PD-door	1
43	PT 308	Stop valve	1
44	4397950	Shaft (C-2600)	8
44.1	4397950	Shaft (C-2600H)	12
45	4397960	Roll, door (C-2600)	8
45.1	4397960	Roll, door (C-2600H)	12
46	KP 261	Door gasket (C-2600)	1
46.1	KP 262	Door gasket (C-2600H)	1
47	4357470	Guide roll	2





## Spare parts list C-2600 PD

<b>Pos.</b>	<b>Code no.</b>	<b>Description</b>	<b>Quantity</b>
48	PI 247	Rotation motor	1
49	PI 220	Limit switch, rotation motor	1
50	3406090	Shaft, upper water chamber AISI	1
51	V171889	Seal set	1
52	1365930	Upper water chamber	1

### Electrical parts / electrical control box

PI 027	Cleaning time relay	1
PI 550	Time relay, steam extractor, drainage time	2
PI 011	Contact relay	2
PI 152	Weekly timer	1
PI 612	Thermostat/thermometer	1
PI 613	Temperature probe	1

Please state the serial number of the cleaning machine when ordering spare parts.

## 10.7 Oil skimmer OS-3S

Pos.	Code no.	Description	Quantity
1	2420110A	Scraper	1
2	4350990	Disc	1
3	PK 169	Shaft seal	1
4	PI 073	Gear motor	1
5	1001823	Shaft	1
6	1001821	Montage plate	1

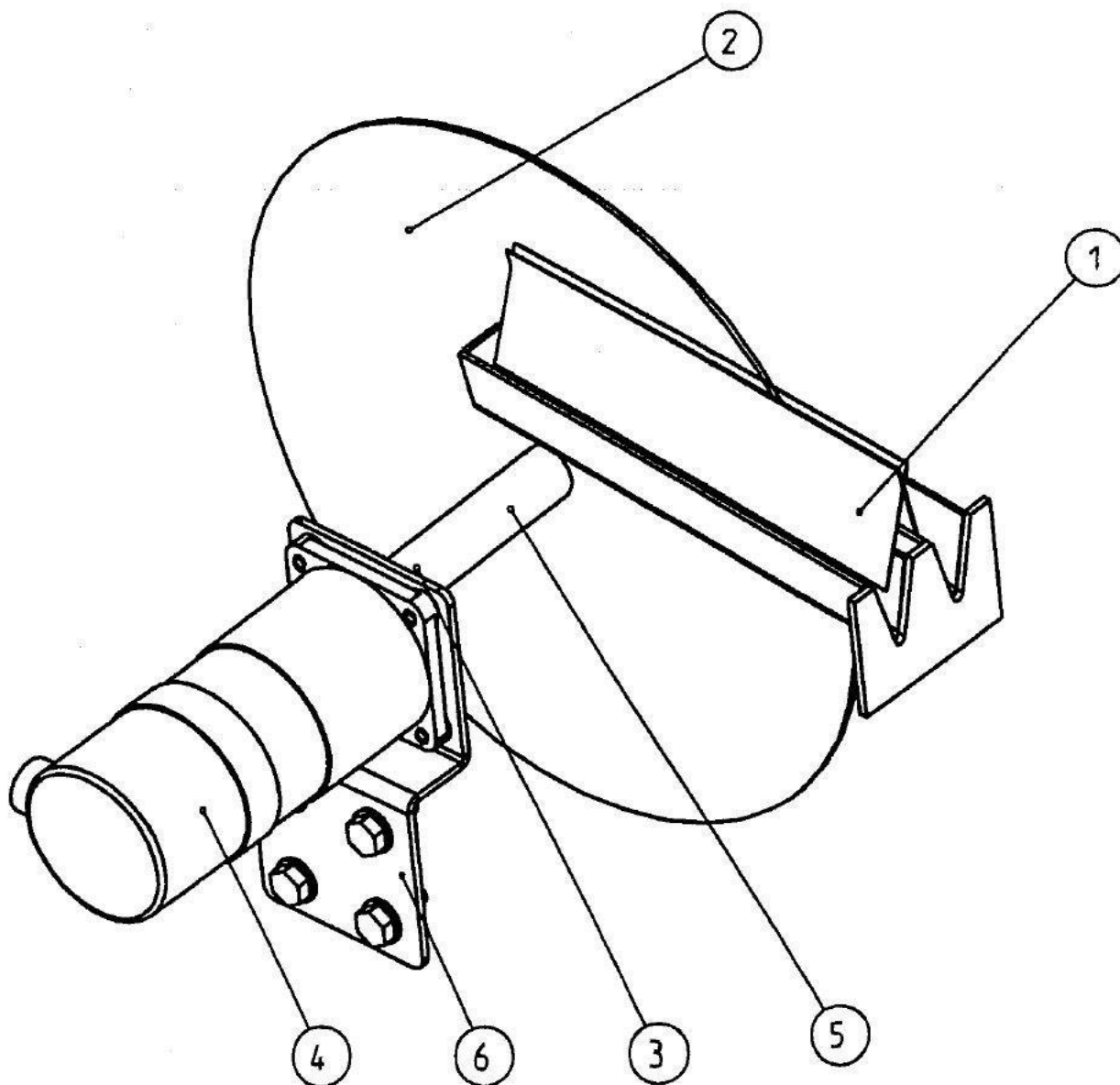

# WATER DISTRIBUTOR STANDARD

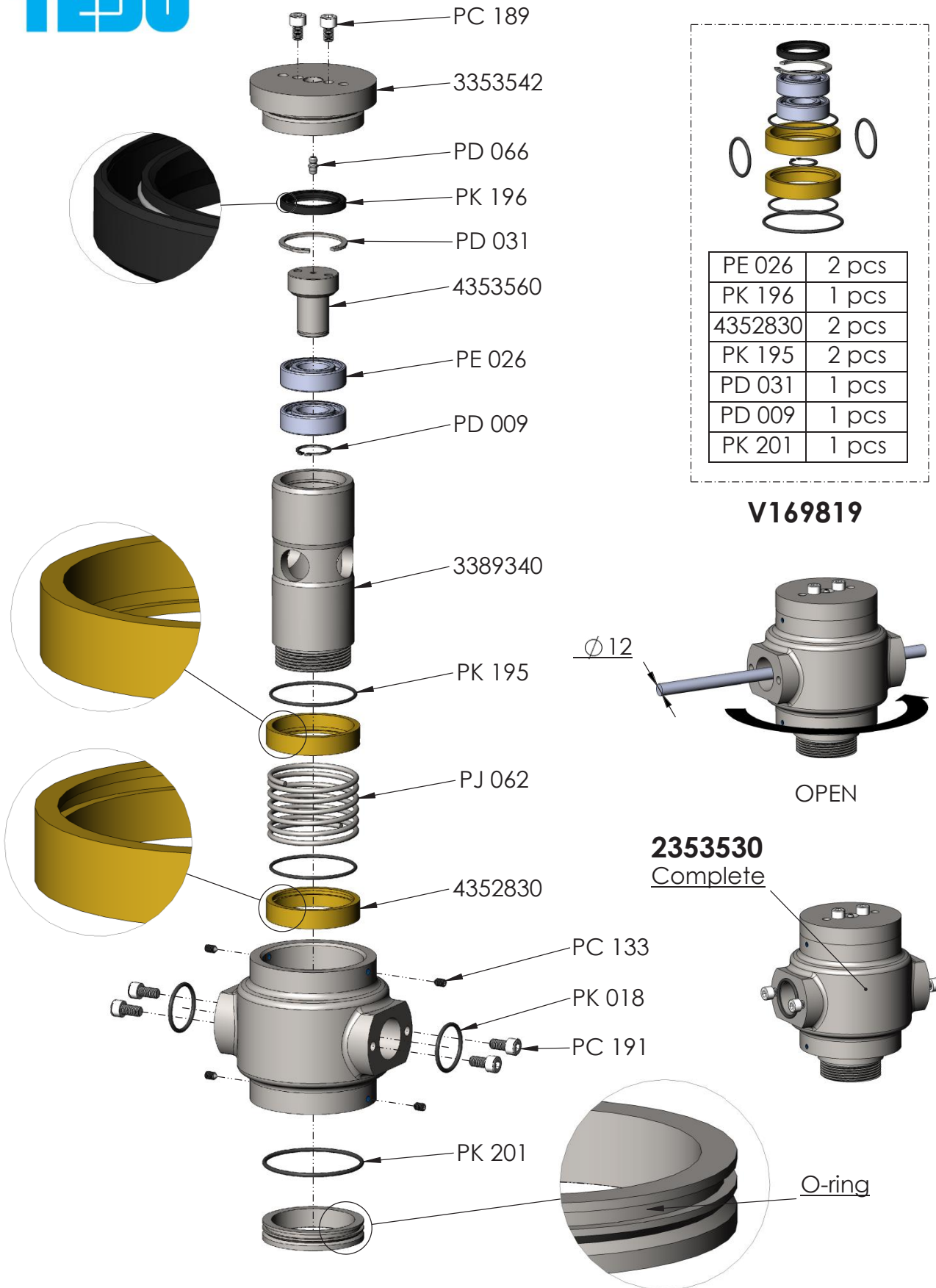

# Du har emnerne som skal afgrates. *Vi har løsningerne!*



***Kom med dine emner  
til vores Test-center.***

I fællesskab finder vi den rette  
brugbare løsning til opgaven.

*Har du spørgsmål er du velkommen til at kontakte vores industri konsulenter*

## **Sjælland**

Muharrem Basaran

2819 2871

[muharrem@pers-group.com](mailto:muharrem@pers-group.com)

## **Jylland**

Kontakt Hovedkontoret

7582 6633

[info@pers-group.com](mailto:info@pers-group.com)

## **Testcenter**

Torben Pers

2819 2875

[torben@pers-group.com](mailto:torben@pers-group.com)