

**Kemi og Maskinløsninger**

# TEJO<sup>®</sup>



## MULTI-STAGE COMPONENT CLEANING MACHINES

For efficient cleaning



Du har emnerne - PERS GROUP har kemi og maskinløsningerne



# Multi-stage cleaning machine

In automated TEIJO multi-stage cleaning machines, a rotary spray system sprays hot cleaning liquid onto stationary parts in a single chamber.

Machine parts:

- CLEANING CHAMBER WITH DOOR
- AUTOMATED SPRAY SYSTEM
- TWO OR THREE LIQUID TANKS
- HEATING AND FILTRATION SYSTEM
- AUTOMATED WATER REFILL
- AUTOMATED DOOR OPENING
- LOAD CARRIAGE AND LOAD GRATING
- ELECTRICAL CONTROL BOX WITH LOGIC CONTROL

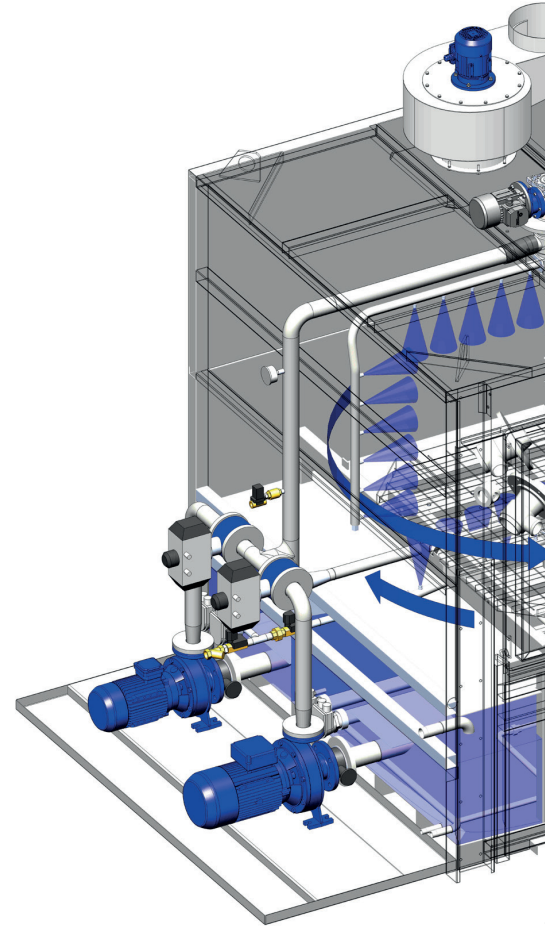

## Why choose a multi-stage machine?

Because of the increasing demands regarding cleanliness and surface finishing, just one cleaning cycle is not enough; one or two additional rinsing stages are required to achieve the desired results.

## Closed cleaning liquid system

In TEIJO cleaning machines, cleaning liquid is circulated in a closed system where it is filtered and reused. The liquid consists of water and 1-5% of cleaning detergent depending on how dirty the parts to be washed are.

The service life of the liquid varies between one week and several months depending on:

- HOW DIRTY THE PARTS TO BE WASHED ARE
- DEGREE OF UTILIZATION
- TYPE OF PROCESS
- REQUIRED RESULT
- FILTRATION SYSTEM
- OIL SEPARATION SYSTEM

Examples of the many functions of TEIJO multi-stage cleaning machines:

- ALKALINE CLEANING AND RINSING  
2-3 STAGES
- WAX REMOVAL AND RINSING  
2-4 STAGES
- ALKALINE CLEANING, DESCALING AND RINSING  
3-5 STAGES
- PHOSPHATING AND RINSING  
3-5 STAGES



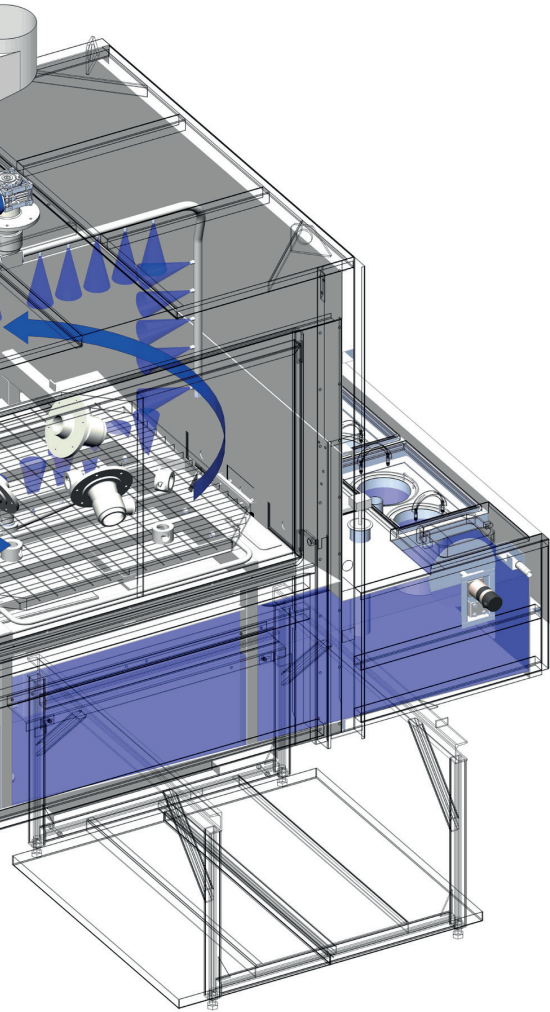

# Applications

Multi-stage cleaning machines have many industrial uses, such as pre-cleaning and cleaning.

## PRE-CLEANING

- CLEANING OF COMPONENTS BEFORE WELDING
- REMOVAL OF ANTI-CORROSIVE TREATMENT BEFORE MACHINING
- CLEANING OF ENGINES AND ENGINE PARTS
- DESCALING OF CYLINDER HEADS ETC.

## CLEANING DURING MACHINING AND ASSEMBLY

- CLEANING OF MACHINED PARTS
- CLEANING AND ANTI-CORROSIVE TREATMENT BEFORE AND AFTER INTERMEDIATE STORING
- CLEANING OF PARTS BEFORE FINAL ASSEMBLY
- PHOSPHATING OF PARTS PRIOR TO PAINTING

# Clients

TEIJO multi-stage cleaning machines can be utilized by for example:

- ENGINEERING INDUSTRY
- CAR AND TRUCK INDUSTRY
- AIRCRAFT AND AIRCRAFT ENGINE INDUSTRY
- ELECTRICAL COMPONENT AND ELECTRIC MOTOR INDUSTRY
- PNEUMATIC AND HYDRAULIC INDUSTRY
- HARDENING PLANTS
- PAINTSHOPS
- INDUSTRIAL REPAIR SHOPS
- RAILWAY REPAIR SHOPS
- ENGINE MACHINING SHOPS
- REPAIR SHOPS FOR THE ARMED FORCES

## TEIJO® - economical

- EFFICIENT FILTERING EXTENDS THE SERVICE LIFE OF THE WASHING FLUID
- GOOD INSULATION REDUCES HEAT LOSS
- DETERGENT COSTS ARE LOW
- THANKS TO THE SHUT-OFF VALVE FOR THE PUMP, MAINTENANCE CAN BE CARRIED OUT WITHOUT DRAINING THE TANK.

## TEIJO® - safe and eco-friendly

- THE CLOSED CIRCULATION OF CLEANING LIQUID IS SAFE AND ENVIRONMENTALLY-FRIENDLY
- THE CLOSED CLEANING CHAMBER AND EFFICIENT STEAM EXTRACTION (OPTIONAL) PREVENT STEAM FROM ENTERING THE WORK ENVIRONMENT
- MOST ALKALINE DETERGENTS ARE BIODEGRADABLE
- THE OIL COMING OFF OF THE COMPONENTS DURING THE CLEANING CYCLE CAN BE SEPARATED FROM THE CLEANING LIQUID USING AN OIL SEPARATOR (OPTIONAL)

# Machine sizes

The standard product range includes five size options. There are two standard height options of the washing chamber: 800 and 1200 mm. Models C-1000 and C-1200 have two tanks; the other machines are available in both two and three tank options. In standard assembly, the machines have one pneumatic door, but a two-door option is available on request.

All machines can be equipped with a loading platform. Models C-1000 – C-2000 can be equipped with either a load platform or a load trolley. In addition, powered feeding of the load carriage is available for heavy loads.

All machines are made of stainless steel.

Our range of industrial cleaning machines is versatile, and we can further customize our products based on the customers' requirements.

## TECHNICAL DATA

Model	Power consumption kW / A	Tanks			
		Heating capacity			
		Tank 1	Tank 2	Tank 3	Tank 4
<b>Machines with 2 tanks</b>					
C-1000-22SS	28 / 50	18	9	-	-
C-1000-22HSS	28 / 50	18	9	-	-
C-1200-22SS	37 / 63	24	12	-	-
C-1200-22HSS	37 / 63	24	12	-	-
C-1600-22SS	49 / 80	24	24	-	-
C-1600-22HSS	49 / 80	24	24	-	-
C-2000-22SS	61 / 100	36	24	-	-
C-2000-22HSS	61 / 100	36	24	-	-
C-2600-22SS	85 / 160	48	36	-	-
C-2600-22HSS	85 / 160	48	36	-	-
<b>Machines with 3 tanks</b>					
C-1600-33SS	61 / 100	24	12	24	-
C-1600-33HSS	61 / 100	24	12	24	-
C-2000-33SS	61 / 100	24	12	24	-
C-2000-33HSS	61 / 100	24	12	24	-
C-2600-33SS	85 / 160	36	24	24	-
C-2600-33HSS	85 / 160	36	24	24	-

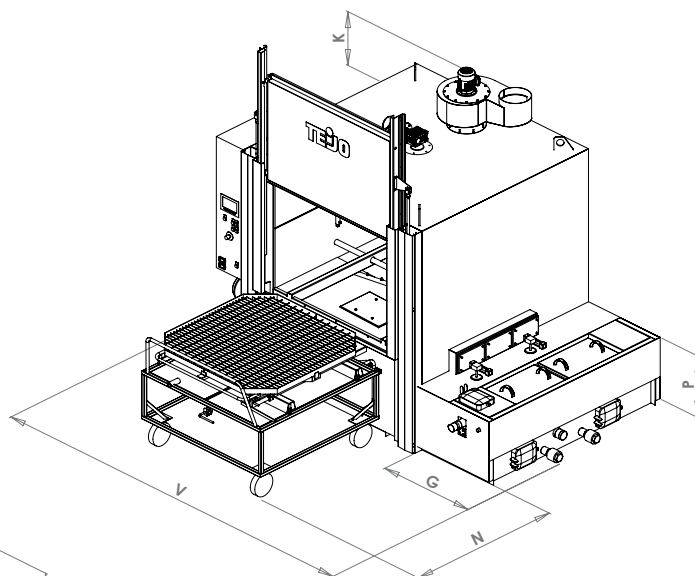
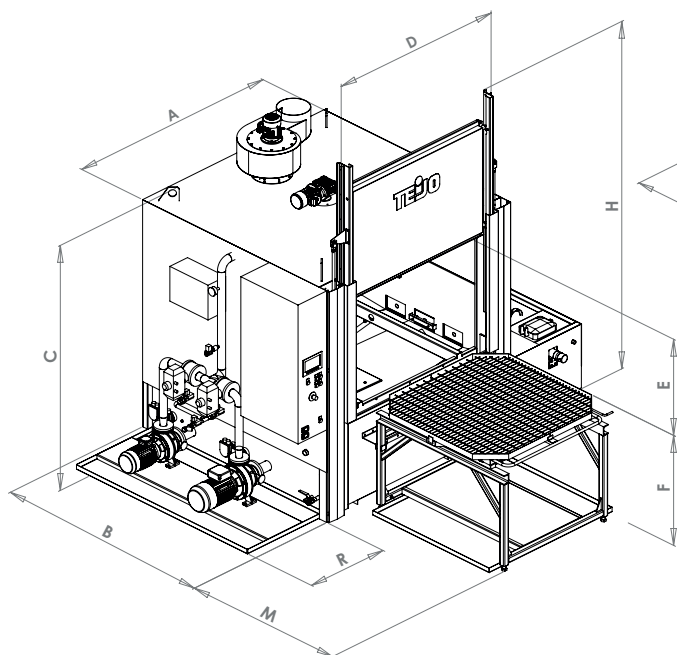

		Pumps						Max. dimensions of washed parts		Max. load	Machine weight
Volume l		Capacity l/min		Pressure kPa		Motor kW		Ø	Height		
Tank 1	Tank 2	Tank 1	Tank 2	Tank 1	Tank 2,3	Tank 1	Tank 2,3			kg	kg
550	450	250	190	410	250	4,0	2,2	890	800	700	900
550	450	280	230	400	240	4,0	2,2	890	1200	700	980
800	600	270	220	400	240	4,0	2,2	1090	800	700	1000
800	600	400	250	410	230	5,5	2,2	1090	1200	700	1100
1100	900	450	300	400	270	5,5	3,0	1390	800	1000	1350
1100	900	500	330	450	260	7,5	3,0	1390	1200	1000	1500
1500	1000	530	380	450	230	7,5	3,0	1790	800	2000	1800
1500	1000	550	440	440	210	7,5	3,0	1790	1200	2000	2000
2200	1900	660	510	450	280	11,0	4,0	2390	800	3000	2400
2200	1900	750	570	440	260	11,0	4,0	2390	1200	3000	2700

800	700	450	300	400	270	5,5	3,0	1390	800	1000	1450
800	700	500	330	450	260	7,5	3,0	1390	1200	1000	1600
1200	1000	530	380	450	230	7,5	3,0	1790	800	2000	1900
1200	1000	550	440	440	210	7,5	3,0	1790	1200	2000	2100
1700	1900	660	510	450	280	11,0	4,0	2390	800	3000	2600
1700	1900	750	570	440	260	11,0	4,0	2390	1200	3000	2900

## PRINCIPAL DIMENSIONS

Model	Width	Depth	Height	Door width	Washing chamber height	Working height	Width	Height	Height	Length	Length	Height	Width	Grate		Width
	A	B	C	D	E	F	G	H	K	M	N	P	R	S	T	V
C-1000-22SS	1400	1500	2200	900	800	930	800	3050	470	950	1050	700	750	870	220	3080
C-1000-22HSS	1400	1500	2600	900	1200	930	800	3850	470	950	1050	700	750	870	220	3080
C-1200-22SS	1500	1600	2200	1100	800	930	800	3050	470	1050	1150	700	750	950	260	3180
C-1200-22HSS	1500	1600	2600	1100	1200	930	800	3850	470	1050	1150	700	750	950	260	3180
C-1600-22SS/33SS	1900	2000	2200	1400	800	930	800	3050	470	1350	1550	700	800	1250	260	3630
C-1600-22HSS/33HSS	1900	2000	2600	1400	1200	930	800	3850	470	1350	1550	700	800	1250	260	3630
C-2000-22SS/33SS	2300	2415	2200	1800	800	930	800	3050	470	1650	1800	700	950	1550	300	4180
C-2000-22HSS/33HSS	2300	2415	2600	1800	1200	930	800	3850	470	1650	1800	700	950	1550	300	4180
C-2600-22SS/33SS	2900	3000	2200	2400	800	930	800	3050	530	2200	-	700	980	2010	500	4810
C-2600-22HSS/33HSS	2900	3000	2600	2400	1200	930	800	3850	530	2200	-	700	980	2010	500	4810

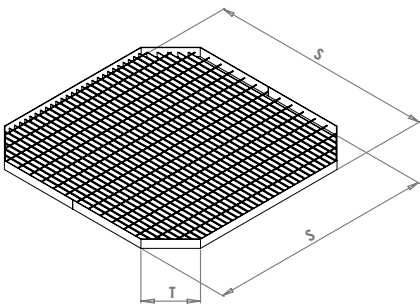

# ACCESSORIES

## Steam extractor DF-250S / DF-3S

The steam extractor starts automatically after the washing cycle, extracting the steam from the machine into the outside air.

Amount of air: 1000/1800 m<sup>3</sup>/h Pressure: 200/250 Pa

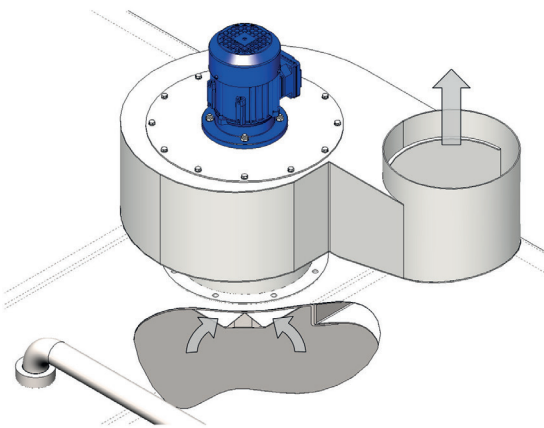

## Overfill protection EC-2

Prevents overfilling of the fluid tank.

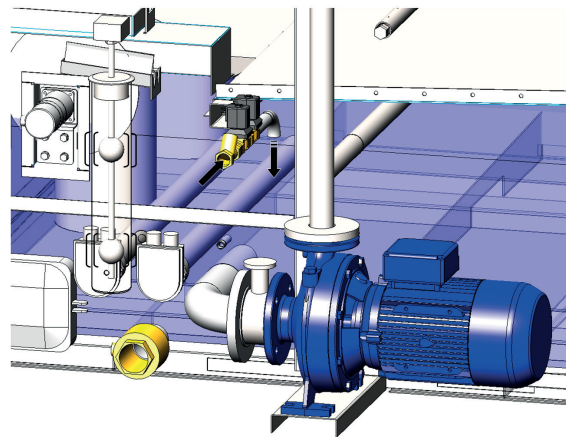

## Detergent dispenser AD-2

Automated dispenser for liquid detergent.

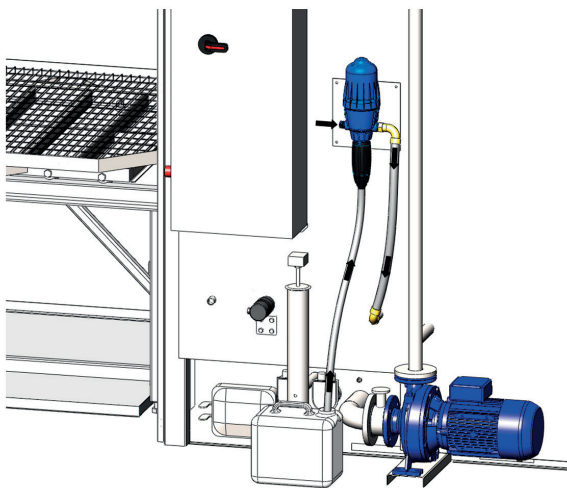

## Oil separator OS-3S

Controlled by a weekly timer, the oil separator removes the demulsified oil from the liquid surface while the cleaning machine is off. The oil separator extends the service life of the cleaning liquid and ensures a good cleaning result.

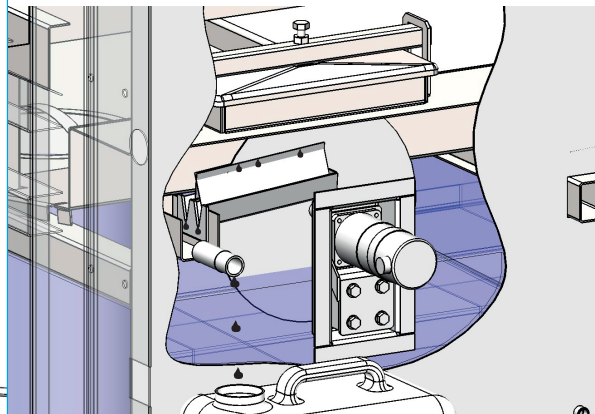



### Oil skimmer OS-300MP

An alternative to the disc separator OS-3S, this skimmer is installed in the shunt circulation current. OS-300MP can be used also during the washing cycle.

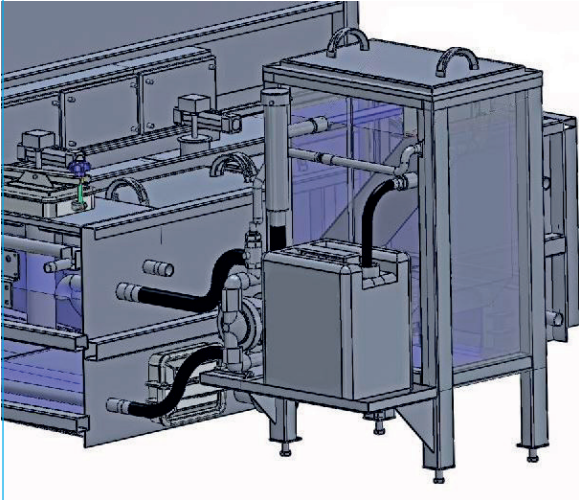

### Spray lance SL-1

for pre-cleaning parts that are very dirty.

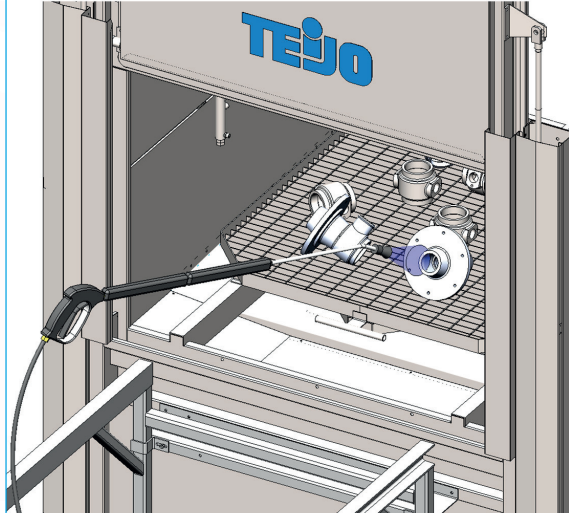

### Suction gun SG-1

Suction gun for removing any liquid remains from the washed parts (components) after the cleaning cycle.

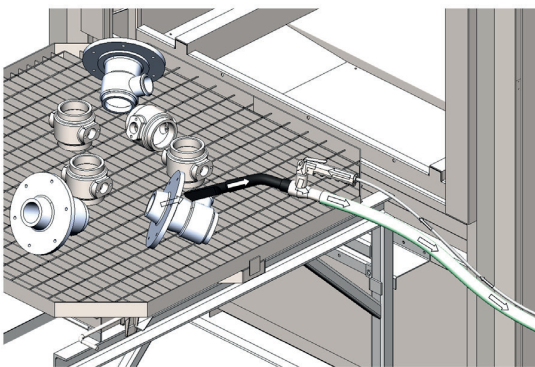

### Other accessories and equipment

- DRAINAGE PUMP
- FULL-FLOW FILTER
- SEPARATE FILTER FOR SHUNT (CURRENT) CIRCULATION
- POWERED FEEDING OF THE LOAD CARRIAGE (MIU/AIU)
- MAGNETIC ROD FOR THE FILTER BASKET
- SINGLE-USE FILTER BAG FOR THE FILTER BASKET
- VARIOUS ROLLER CONVEYORS AND CONVEYOR SYSTEMS AVAILABLE ON REQUEST
- INTEGRATED HOT AIR DRYERS
- MIST COLLECTORS FOR STEAM REMOVAL
- SAFETY BASIN BENEATH THE MACHINE



## FILTERS

### Bypass filter EFG-6

Removes of fines and oils. A pump circulates the liquid through an external filter vessel. The filter vessel is equipped with a special bag that has, in addition to mechanical filtration, the property to remove oils from the liquid flow. Depending on type of oil, up to 20-30 kg of oil can be removed with a bag. A gauge will show the pressure increase in the filter bag. The operation of the bypass filter can be continuous or connected to the cleaning cycle.

Filtering level of the filtration unit depends on the chosen filter bag alternative ~ 5 - 100µm.



46

C-medels

### Throw away filter bag PP041 Locking spring PJ017 for disposable filter bag

Option for occasional need for better filtration, to be inserted in the filter baskets of the machine.

### Magnet bar separator PP048

Option for occasional need for better filtration, to be inserted in the filter baskets of the machine.



47

C-medels



# Vandbaseret affedtning, industri



## Teka Clean 20

Alsidig alkalisk affedtningsmiddel, som ved dets sammensætning tilgodeser affedtningsproblemer, der opstår i forbindelse med blandet produktion. Til jern, stål, aluminium samt let metaller, rød metaller og kunststoffer. Rigtig gode smudsløsende og smuds bærende egenskaber. Temperatur 50-80 grader.

**pH-værdi:(3%):12,6**

## Teka Clean 30

Alsidig mild alkalisk affedtningsmiddel, som ved dets sammensætning tilgodeser affedtningsproblemer, der opstår i forbindelse med blandet produktion. Til jern, stål, aluminium samt let metaller, rød metaller og kunststoffer. Rigtig gode smudsløsende og smuds bærende egenskaber. Temperatur 50-80 grader.

**pH-værdi:(3%):11,2**



## Teka Clean 96

Stærkt alkalisk pulver til spule-, dyppe- og ultralyds aflakering af jern og stål. Fortrinlige smudsløsende og smudsbærende egenskaber. Fuldt biologisk nedbrydeligt.

Lavtskummende og korrosions stabil. Olieseparerende. Arbejds temperatur 60-80 grader.

**pH-værdi:(3%):12,8**

## Teka Clean 320K

Flydende, netutral affedtningsmiddel med temporær korrosionsbeskyttelse.

Velegnet til alle metaltyper, hvis styrke specielt fremtræder i forbindelse med krævende og alligvel skånsom mellemaffedtning af forædlede emner. Produktet er biologisk nedbrydeligt, lavtskummende og specielt velegnet til spule- og højtryksanlæg. **Hurtigseparerende.**

**pH-værdi:(3%):8,1**



## Teka Clean 385

Flydende alkalisk affedtningsmiddel. Produktet er velegnet til blandt andet affedtning af Rustfrit Stål, hvor kraftig indfedtede emner renses effektivt. Arbejdstemperatur: 60-80 °C.

**pH-værdi:(3 %):11,8**

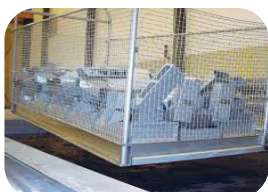

## Teka Clean 387K,

Flydende, miljørigtig affedtningsmiddel med særdeles god korrosionsbeskyttelse. Det er særdeles velegnet til affedtning af jern og stål, hvor olie og fedt fjernes effektivt.

**Korrosionsgrad = 0. Arbejdstemp. 45-85 °C Hurtigseparerende.**

**pH-værdi:(3 %):12,1**

## Teka Clean 387 K24

Universal, basisk, flydende affedtningsmiddel til jern, stål og rustfri stållegeringer, primært til krævende slutaffedtnings opgaver efter polering eller optræk. Anvendes i spuleaffedtning, dyppe og ultralydsproces. Arbejdstemp. 40-65 °C.

**pH-værdi:(3%):11,7**



## Teka Clean 400

Flydende let alkalisk special rengøring - og metal affedtning der effektivt fjerner fedt og olie. Efterlader ingen vandpletter efter vask v/40-75 °C.

**pH-værdi:(3%):9,0**

## Teka Clean 600

Surt affedtningsmiddel til opløsning af såvel fedt og olie samt overfladerust på metalliske overflader. Anvendes i dyppe som ultralydskar og maskiner. Anvendes fortyndet med vand op til 1:20 afhængig af renses effekten.

**pH-værdi:(konc.):5,4**

# Du har emnerne som skal afgrates. *Vi har løsningerne!*



***Kom med dine emner  
til vores Test-center.***

I fællesskab finder vi den rette  
brugbare løsning til opgaven.

*Har du spørgsmål er du velkommen til at kontakte vores industri konsulenter*

## **Sjælland**

Muharrem Basaran

2819 2871

[muharrem@pers-group.com](mailto:muharrem@pers-group.com)

## **Jylland**

Kontakt Hovedkontoret

7582 6633

[info@pers-group.com](mailto:info@pers-group.com)

## **Testcenter**

Torben Pers

2819 2875

[torben@pers-group.com](mailto:torben@pers-group.com)