

Kemi og Maskinløsninger

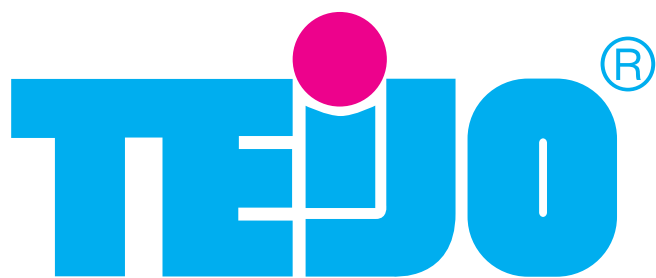

SINGLE-STAGE COMPONENT CLEANING MACHINES

C-800SS...C-2600SS

For efficient cleaning



Du har emnerne - PERS GROUP har kemi og maskinløsningerne



Why use a water-based cleaning method?

Requirements for speed and efficiency as well as increasingly stringent environmental regulations have led to a situation where it is worth making the transition from solvent cleaning to safer water-based cleaning methods. Alkaline cleaning using a TEIJO cleaning machine is an efficient and economical method.

Component cleaning machines

The TEIJO cleaning machines clean components automatically in a cleaning chamber where rotating spray piping sprays hot washing fluid onto the components being washed.

MACHINE COMPONENTS:

- CLEANING CHAMBER
- ROTATING SPRAY PIPES
- PUMP
- HEATING SYSTEM
- FILTER SYSTEM
- LEVEL MONITORING
- LOAD CARRIAGE AND GRATING
- SWITCHGEAR WITH OPERATING SWITCHES

Closed fluid circulation

TEIJO cleaning machines circulate the washing fluid (water and 2–5% alkaline cleaning agent) in a closed system, filter it and reuse it. The maximum temperature of the washing fluid is +80 °C. The service life of the fluid depends on the application. It is impacted by the cleaning machine's use rate and the dirtiness of the components being washed, the oil coming off the components in particular.

Applications

This machine type is suitable for component cleaning, for example, at

- CAR AND LORRY REPAIR SHOPS
- ENGINE MACHINING SHOPS
- CAR ELECTRICS REPAIR SHOPS
- VOCATIONAL EDUCATION INSTITUTIONS
- INDUSTRIAL REPAIR SHOPS
- PUMP REPAIR SHOPS
- ELECTRIC MOTOR REPAIR SHOPS

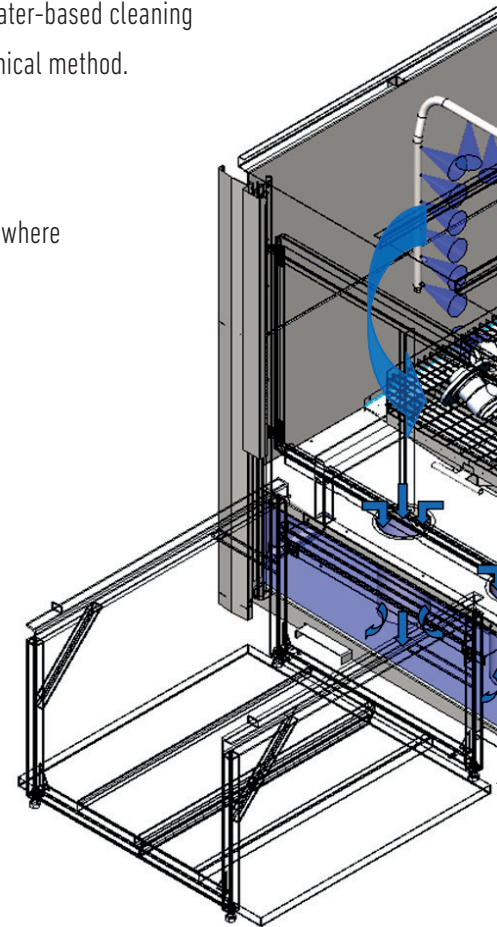

In engineering industry manufacture, these machines are used for

- COMPONENT CLEANING BEFORE WELDING
- REMOVING ANTI-CORROSIVE AGENTS BEFORE MACHINING
- CLEANING MACHINED COMPONENTS
- MAINTENANCE

Why TEIJO®?

- EXCELLENT CLEANING RESULT
- CLEANING IN A CLOSED CHAMBER
- ROTATING SPRAY PIPES
- LARGE FLUID TANK
- SHORT HEATING TIME
- RELIABLE AND EASY-TO-USE
- MINIMUM MAINTENANCE
- THERMALLY INSULATED STRUCTURE



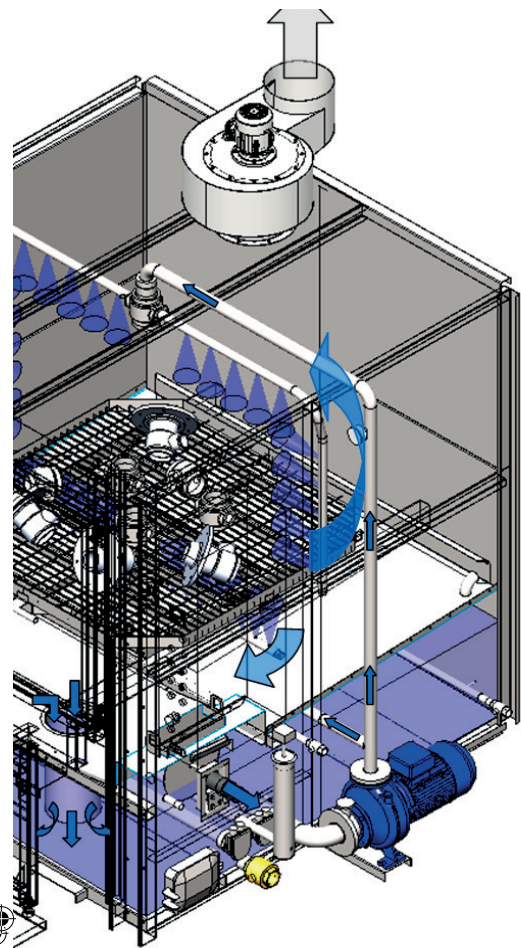

Standard equipment

- HINGED DOOR OR PNEUMATIC LIFTING DOOR
- ROTATING SPRAY PIPES
- LOAD CARRIAGE AND GRATING
- SHUT-OFF VALVE ON THE PUMP'S SUCTION SIDE
- FILTER BASKET
- LEVEL SENSOR
- CLEANING DOOR AND DRAIN VALVE
- SWITCHGEAR WITH OPERATING SWITCHES
- PRESSURE GAUGE
- TOP SPRAY PIPE ROTATION SENSOR
- TANK BOTTOM FLUSH PIPING (EXCL. C-800SS)
- TIMER FOR HEATING AND OIL SEPARATOR
- ADJUSTABLE THERMOSTAT CONTROLLED TEMPERATURE CONTROL

Product range

The TEIJO product range includes practically all types of spray cleaning machines.

In addition to the single-stage component cleaning machines, the product range comprises

- MULTI-STAGE CLEANING MACHINES FOR MORE DEMANDING APPLICATIONS AND PHOSPHATING
- TUNNEL CLEANING MACHINES WITH A CHAIN OR NET CONVEYOR
- SPECIAL CLEANING MACHINES TO BE INTEGRATED INTO AUTOMATIC MACHINING LINES
- CLEANING MACHINES MANUFACTURED ACCORDING TO CUSTOMER REQUIREMENTS

TEIJO® - economical

- EFFICIENT FILTERING EXTENDS THE SERVICE LIFE OF THE WASHING FLUID
- GOOD INSULATION REDUCES HEAT LOSS
- DETERGENT COSTS ARE LOW
- THE PUMP'S SHUT-OFF VALVE ENABLES PERFORMING MAINTENANCE WITHOUT DRAINING THE FLUID TANK

TEIJO® - safe and eco-friendly

- THE CLOSED CIRCULATION OF CLEANING LIQUID IS SAFE AND ECO-FRIENDLY
- THE CLOSED WASHING CHAMBER AND EFFICIENT STEAM REMOVAL (ACCESSORY) PREVENT STEAM FROM ESCAPING INTO THE WORK ENVIRONMENT
- MOST ALKALINE DETERGENTS ARE BIODEGRADABLE
- THE OIL COMING OFF THE COMPONENTS BEING WASHED CAN BE SEPARATED FROM THE WASHING FLUID USING AN OIL

Machine sizes

The product range comprises six machine sizes C-800SS...C-2600SS.

This number indicates the top spray pipe's rotational diameter in millimetres.

There are two door type options:

- the hinged door KD; machines C-800SS...C-1600SS
- the pneumatic lifting door PD1; machines C-800SS...C-2600SS

The machines equipped with the pneumatic lifting door can be equipped with either the fixed load platform (LP) or load trolley (LT).

All machines are manufactured from stainless steel.

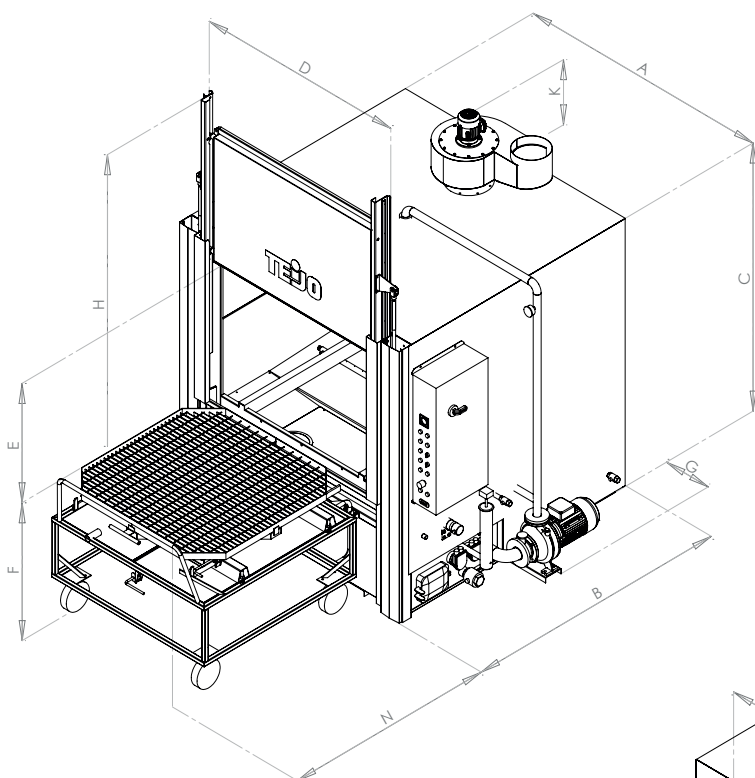

Cleaning machine with pneumatic lifting door and load trolley C-800SS-PD1...C-2000SS-PD1

Cleaning machine with hinged door
C-800SS-KD...C-1600SS-KD

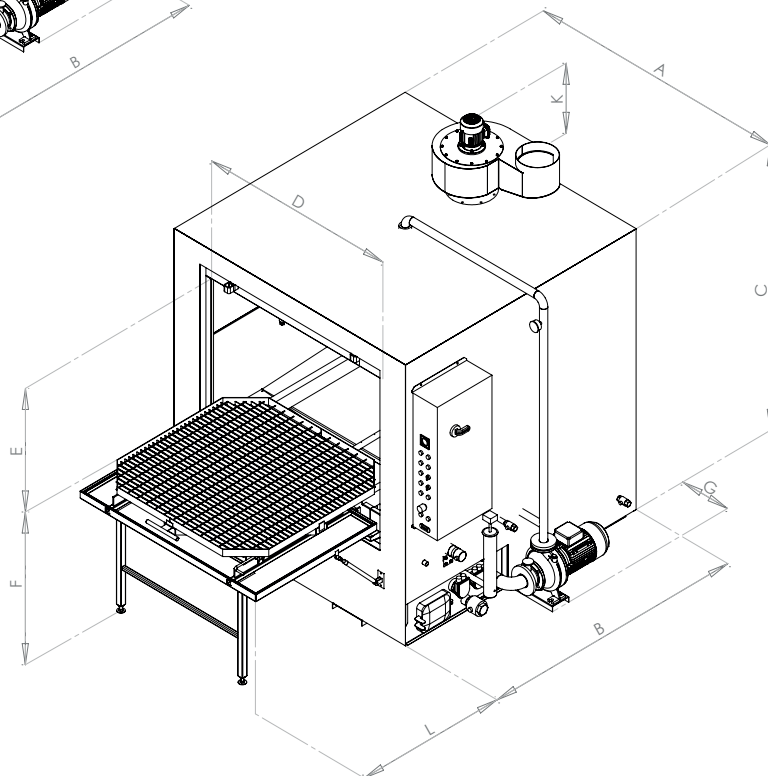

TECHNICAL DATA

Model	Connection power kW/A	Fluid tank		Pump			Maximum dimensions of the component being cleaned		Maximum load kg	Machine weight kg
		Heating power	Volume	Flow	Pressure	Motor	Ø	Height		
		kW	l	l/min	kPa	kW				
C-800SS	14/25	9	350	200	400	4,0	690	550	500	400
C-1000SS	17/32	12	650	230	400	4,0	890	800	500	650
C-1000HSS	17/32	12	650	250	400	4,0	890	1200	500	750
C-1200SS	19/32	18	800	350	400	4,0	1090	800	700	750
C-1200HSS	19/32	18	800	370	400	5,5	1090	1200	700	850
C-1600SS	25/50	24	1300	380	400	5,5	1390	800	700	1000
C-1600HSS	25/50	24	1300	400	450	7,5	1390	1200	700	1100
C-2000SS	37/63	36	1900	430	450	7,5	1790	800	1000	1300
C-2000HSS	37/63	36	1900	450	450	7,5	1790	1200	1000	1500
C-2600SS	49/80	48	3100	660	450	11,0	2390	800	2500	2000
C-2600HSS	49/80	48	3100	700	450	11,0	2390	1200	2500	2200

PRINCIPAL DIMENSIONS

Model	Width	Depth	Chamber height / Max Height	Door opening	Cleaning chamber height	Working-height	Width	Height	KD-model length	Length	Length	Grid platform	
	A	B	C	D	E	F	G	H	L	M	N	S	T
C-800SS	1150	1200	1600 / 1750	700	550	800	400	2350	750	850	900	655	220
C-1000SS	1400	1500	2000 / 2150	900	800	930	400	3050	1100	950	1050	870	220
C-1000HSS	1400	1500	2400 / 2550	900	1200	930	400	3850	-	950	1050	870	220
C-1200SS	1600	1700	2000 / 2150	1100	800	930	400	3050	1100	1050	1150	950	260
C-1200HSS	1600	1700	2400 / 2550	1100	1200	930	400	3850	1500	1050	1150	950	260
C-1600SS	1900	2000	2000 / 2150	1400	800	930	400	3050	1100	1350	1550	1250	260
C-1600HSS	1900	2000	2400 / 2550	1400	1200	930	400	3850	1500	1350	1550	1250	260
C-2000SS	2300	2400	2000 / 2150	1800	800	930	400	3050	-	1650	1800	1550	300
C-2000HSS	2300	2400	2400 / 2550	1800	1200	930	400	3850	1500	1650	1800	1550	300
C-2600SS	2900	3000	2000 / 2150	2400	800	930	400	3150	-	2200	-	2050	500
C-2600HSS	2900	3000	2400 / 2550	2400	1200	930	400	3950	-	2200	-	2050	500

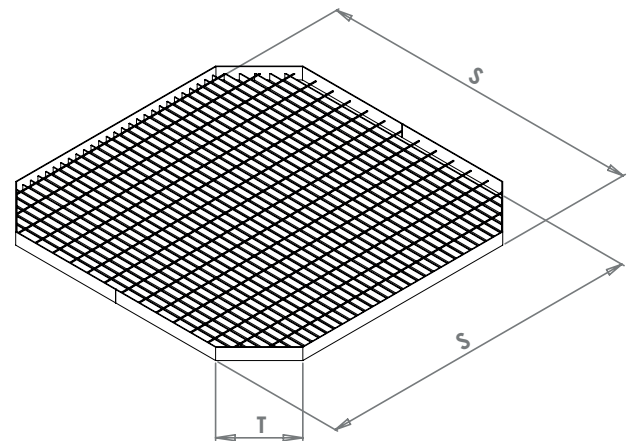
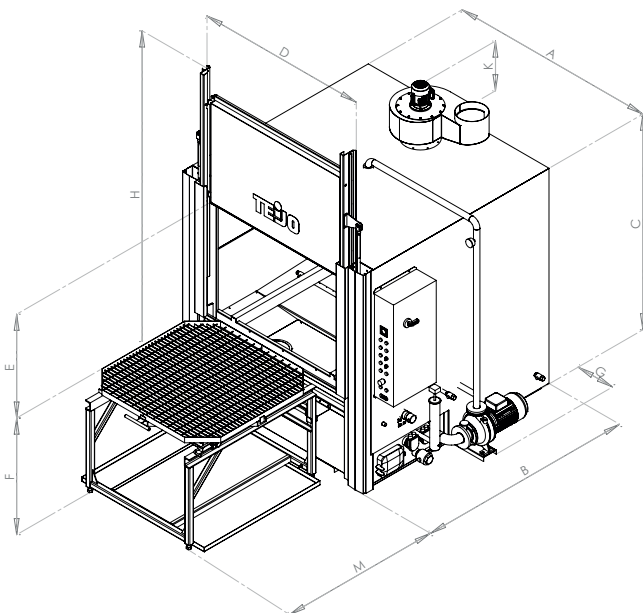

Cleaning machine with pneumatic lifting door and load platform C-800SS-PD1...C-2600SS-PD1

Subject to change without notice

ACCESSORIES

Oil skimmer OS-3S

Controlled by a weekly timer, the oil skimmer removes the demulsified oil from the liquid surface while the cleaning machine is off. The oil skimmer extends the service life of the cleaning liquid and ensures a good cleaning result.

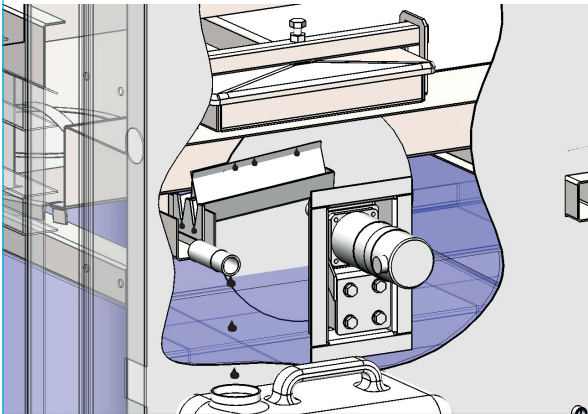

Steam extractors DF-250S / DF-3S

The steam extractor starts automatically after cleaning and removes steam from the machine into the outside air.

Amount of air: 1000/1800 m³/h

Pressure: 200/250 Pa

Installation height (K): 500/600 mm

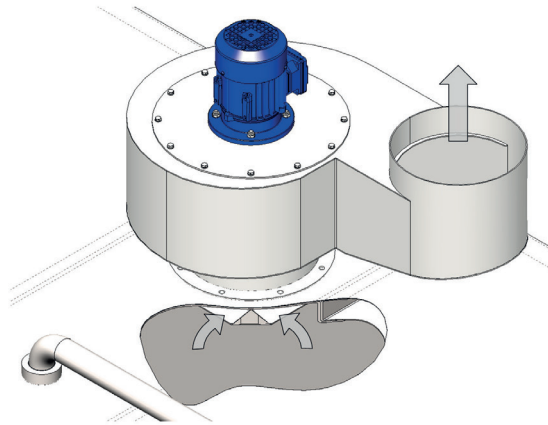

Automatic refilling AR-2

The automatic water refilling keeps the level in the fluid tank at the standard height.

Overfill protection EC-2

Prevents overfilling of the fluid tank.

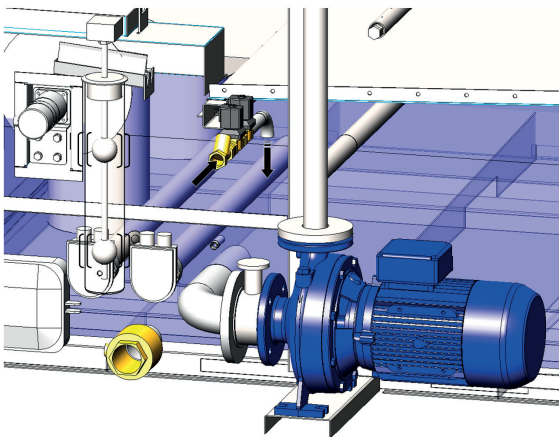

Detergent dispenser AD-6

Automated dispenser for liquid detergent.

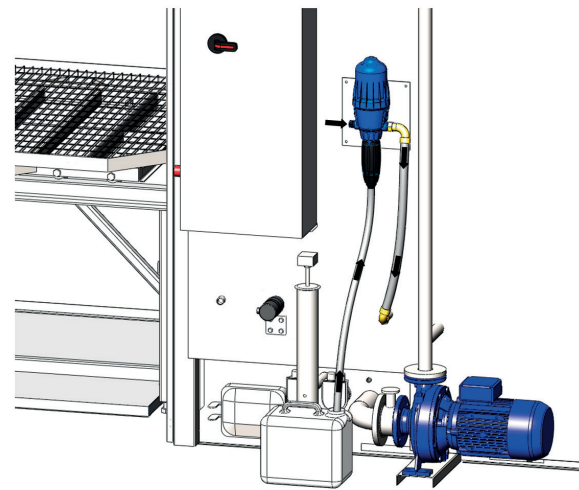

Spray pipe mechanical rotation MR-2S

The top spray pipe rotated by a motor ensures the best possible cleaning result.

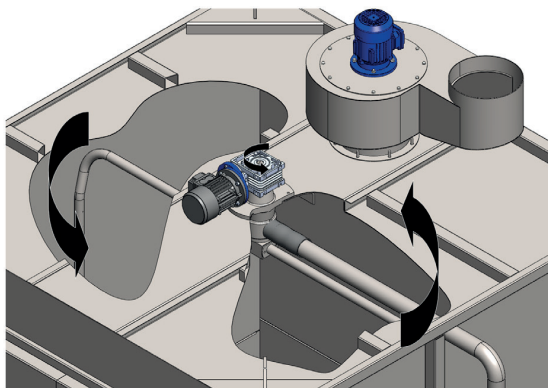

Spray lance SL-1

for pre-cleaning parts that are very dirty.

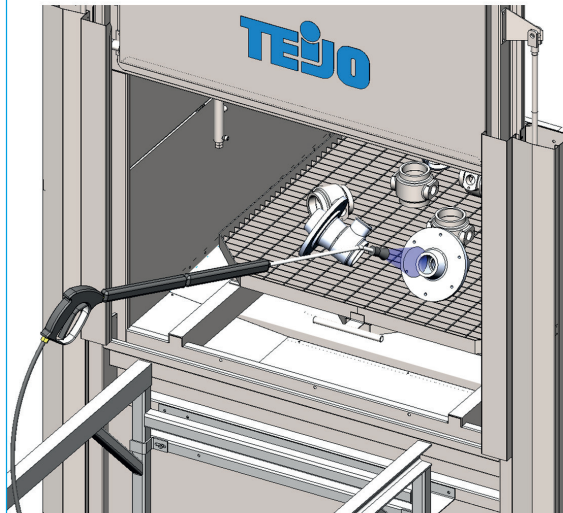

Suction gun SG-1

Suction gun for removing any liquid remains from the washed parts (components) after the cleaning cycle.

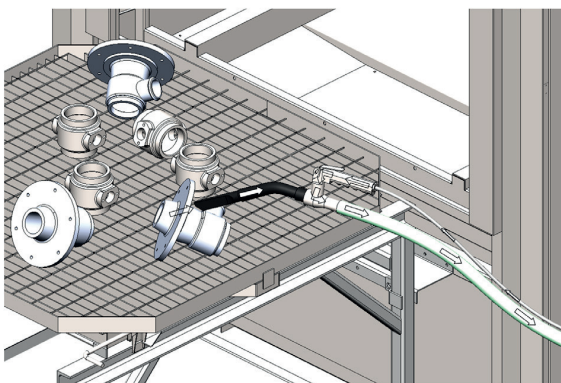

Other accessories and equipment

- EMPTYING PUMP
- FULL-FLOW FILTER
- SEPARATE FILTER FOR SHUNT (CURRENT) CIRCULATION
- POWERED FEEDING OF THE LOAD CARRIAGE (MIU/AIU)
- MAGNETIC ROD FOR THE FILTER BASKET
- SINGLE-USE FILTER BAG FOR THE FILTER BASKET
- VARIOUS ROLLER CONVEYORS AND CONVEYOR SYSTEMS AVAILABLE ON REQUEST
- INTEGRATED HOT AIR DRYERS
- MIST COLLECTORS FOR STEAM REMOVAL
- SAFETY BASIN BENEATH THE MACHINE



Du har emnerne - PERS GROUP har kemi og maskinløsningerne

Vandbaseret affedtning, industri



Teka Clean 20

Alsidig alkalisk affedtningsmiddel, som ved dets sammensætning tilgodeser affedtningsproblemer, der opstår i forbindelse med blandet produktion. Til jern, stål, aluminium samt let metaller, rød metaller og kunststoffer. Rigtig gode smudsløsende og smuds bærende egenskaber. Temperatur 50-80 grader.

pH-værdi:(3%):12,6

Teka Clean 30

Alsidig mild alkalisk affedtningsmiddel, som ved dets sammensætning tilgodeser affedtningsproblemer, der opstår i forbindelse med blandet produktion. Til jern, stål, aluminium samt let metaller, rød metaller og kunststoffer. Rigtig gode smudsløsende og smuds bærende egenskaber. Temperatur 50-80 grader.

pH-værdi:(3%):11,2

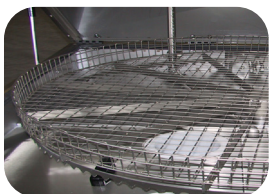

Teka Clean 96

Stærkt alkalisk pulver til spule-, dyppe- og ultralyds aflakering af jern og stål. Fortrinlige smudsløsende og smudsbærende egenskaber. Fuldt biologisk nedbrydeligt.

Lavtskummende og korrosions stabil. Olieseparerende. Arbejds temperatur 60-80 grader.

pH-værdi:(3%):12,8

Teka Clean 320K

Flydende, netutral affedtningsmiddel med temporær korrosionsbeskyttelse.

Velegnet til alle metaltypen, hvis styrke specielt fremtræder i forbindelse med krævende og alligvel skånsom mellemaffedtning af forædlede emner. Produktet er biologisk nedbrydeligt, lavtskummende og specielt velegnet til spule- og højtryksanlæg. **Hurtigseparerende.**

pH-værdi:(3%):8,1



Teka Clean 385

Flydende alkalisk affedtningsmiddel. Produktet er velegnet til blandt andet affedtning af Rustfrit Stål, hvor kraftig indfedtede emner renses effektivt. Arbejdstemperatur: 60-80 °C.

pH-værdi:(3 %):11,8

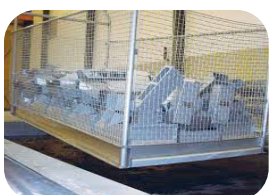

Teka Clean 387K,

Flydende, miljørigtig affedtningsmiddel med særdeles god korrosionsbeskyttelse. Det er særdeles velegnet til affedtning af jern og stål, hvor olie og fedt fjernes effektivt.

Korrosionsgrad = 0. Arbejdstemp. 45-85 °C **Hurtigseparerende.**

pH-værdi:(3 %):12,1

Teka Clean 387 K24

Universal, basisk, flydende affedtningsmiddel til jern, stål og rustfri stållegeringer, primært til krævende slutaffedtnings opgaver efter polering eller optræk. Anvendes i spuleaffedtning, dyppe og ultralydsproces. Arbejdstemp. 40-65 °C.

pH-værdi:(3%):11,7



Teka Clean 400

Flydende let alkalisk special rengøring - og metal affedtning der effektivt fjerner fedt og olie. Efterlader ingen vandpletter efter vask v/40-75 °C.

pH-værdi:(3%):9,0

Teka Clean 600

Surt affedtningsmiddel til opløsning af såvel fedt og olie samt overfladerust på metalliske overflader. Anvendes i dyppe som ultralydskar og maskiner. Anvendes fortyndet med vand op til 1:20 afhængig af rensningseffekten.

pH-værdi:(konc.):5,4

Du har emnerne som skal afgrates. *Vi har løsningerne!*



***Kom med dine emner
til vores Test-center.***

I fællesskab finder vi den rette
brugbare løsning til opgaven.

Har du spørgsmål er du velkommen til at kontakte vores industri konsulenter

Sjælland

Muharrem Basaran

2819 2871

muharrem@pers-group.com

Jylland

Kontakt Hovedkontoret

7582 6633

info@pers-group.com

Testcenter

Torben Pers

2819 2875

torben@pers-group.com