

TEJO®



TOP-LOADING COMPONENT CLEANING MACHINES TL-650SS...TL-1150SS

For efficient cleaning



PERS
INDUSTRIVEJ 12-16
7120 VEJLE Ø
75 82 66 33

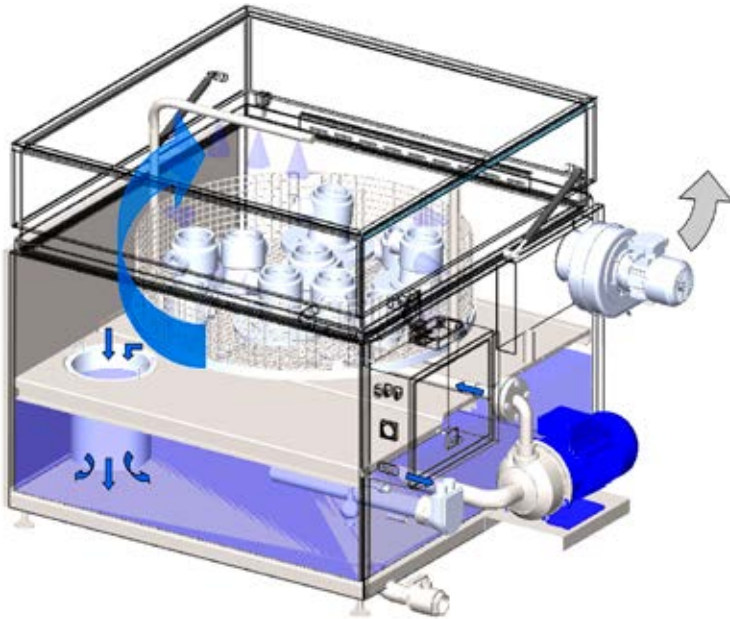

Why water-based cleaning?

Due to high speed and efficiency requirements as well as tightened environmental regulations, it is advisable to move from solvent cleaning to safer, water-based cleaning methods. An efficient, economical method is alkaline cleaning with a TEIJO cleaning machine.

Component cleaning machines

In TEIJO cleaning machines, the selected cleaning cycle is carried out automatically.

PARTS OF THE MACHINE:

- CLEANING CHAMBER
- ROTARY SPRAY PIPING
- PUMP
- HEATING SYSTEM
- FILTER SYSTEM
- FLUID LEVEL MONITORING
- CLEANING TABLE AND LOAD BASKET
- ELECTRICAL CONTROL BOX WITH OPERATING SWITCHES
- ADJUSTABLE THERMOSTAT CONTROLLED TEMPERATURE CONTROL

Closed fluid circulation

In TEIJO cleaning machines, the washing fluid (water and 1–5% alkaline detergent) circulates in a closed system, and is filtered and reused. The maximum temperature of the washing fluid is 80 °C. The service life of the fluid varies depending on the application. It is affected by the utilisation rate of the cleaning machine and the dirtiness of the components cleaned, particularly the oil coming off into the fluid.

Applications

This machine type is suitable for cleaning components at, for example:

- CAR AND LORRY REPAIR SHOPS
- ENGINE MACHINING SHOPS
- CAR ELECTRICS REPAIR SHOPS
- VOCATIONAL INSTITUTIONS
- INDUSTRIAL REPAIR SHOPS

In industrial production of machine workshops, these machines are used for:

- CLEANING COMPONENTS BEFORE WELDING
- REMOVING ANTI-RUST AGENTS BEFORE MACHINING
- CLEANING MACHINED PARTS AND COMPONENTS
- MAINTENANCE (CLEANING NEEDS)

Why TEIJO®?

- EXCELLENT CLEANING RESULTS
- CLEANING IN A CLOSED CHAMBER
- ROTARY SPRAY PIPING
- LARGE FLUID TANK
- SHORT HEATING TIME
- LOADING HEIGHT ONLY 780 MM
- RELIABLE AND EASY-TO-USE
- ALMOST MAINTENANCE-FREE

TEIJO® - economical

- EFFICIENT FILTERING EXTENDS THE SERVICE LIFE OF THE WASHING FLUID.
- GOOD INSULATION REDUCES HEAT LOSS.
- DETERGENT COSTS ARE LOW.

TEIJO® - safe and eco-friendly

- THE CLOSED CIRCULATION OF WASHING FLUID IS SAFE AND ENVIRONMENTALLY-FRIENDLY.
- THE CLOSED CLEANING CHAMBER AND EFFICIENT VAPOUR REMOVAL (OPTIONAL) PREVENT VAPOUR FROM ENTERING THE WORK ENVIRONMENT.
- MOST ALKALINE DETERGENTS ARE BIODEGRADABLE.
- THE OIL COMING OFF THE COMPONENTS CLEANED CAN BE SEPARATED FROM THE WASHING FLUID USING AN OIL SEPARATOR (OPTIONAL).
- ELECTRONIC SAFETY LOCKING OF THE LID DURING CLEANING.

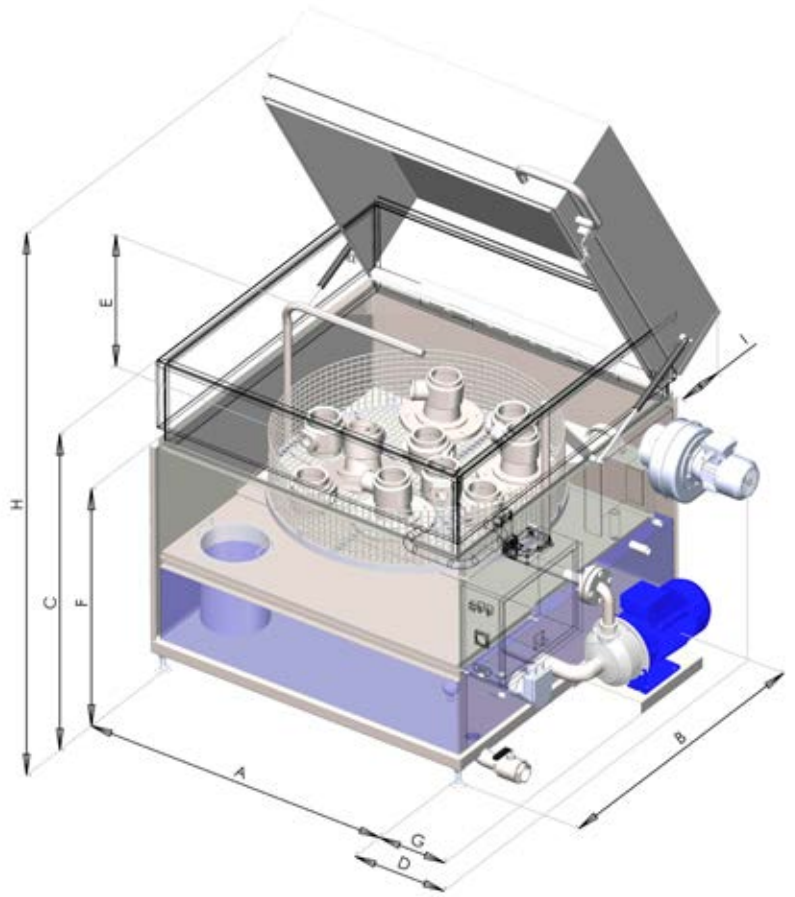

MAIN DIMENSIONS mm

		TL-650SS	TL-900SS	TL-1150SS
Width	A	900	1100	1350
Depth	B	900	1100	1350
Height	C	1070	1070	1070
Rotation diameter		650	900	1150
Load basket diameter		630	850	-
Width	D	340	340	340
Cleaning height	E	430	430	430
Working height	F	780	780	780
Width	G	280	280	280
Height	H	1985	2010	2150
Depth	I	235	225	235

TECHNICAL DATA

		TL-650SS	TL-900SS	TL-1150SS
Connection power	kW	8	11	11
Fuse rating		3 x 16 A	3 x 25 A	3 x 25 A
Heating capacity	kW	6	9	9
Tank volume	l	200	350	550
Pump, capacity	l/min	200	230	250
Pump, pressure	bar	2,5	2,3	2,5
Pump, motor	kW	2,2	2,2	2,2
Load	kg	150	150	150
Machine weight	kg	230	270	400
Filter, separation	micron	630	630	630
Insulation	mm	15	15	15
Noise level	dba	70	70	70

Machine sizes

Top-loading machines are manufactured in three sizes, TL-650SS, TL-900SS and TL-1150SS. They are made of stainless steel.

TEIJO® - product range

The TEIJO product range also includes single- and multi-stage cleaning machines as well as tunnel and special cleaning machines.

COMPONENT CLEANING MACHINES | ACCESSORIES

Steam extractor DF-1 and adapter DFO-110

The steam extractor fan starts automatically after the cleaning cycle, removing the steam from the machine into the outside air.

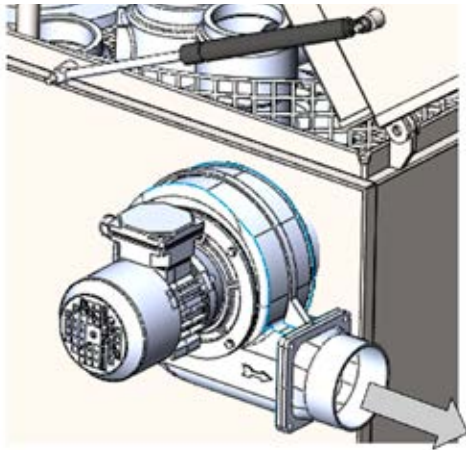

Detergent dispenser AD-2

The liquid detergent dispenser together with automatic refilling AR-1 helps to maintain the desired mixture ratio of the cleaning fluid.

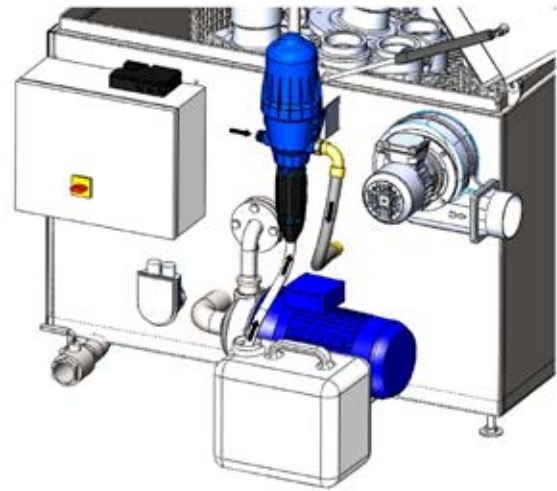

Oil separator TEIJO OS-3B

Controlled by a weekly timer, the oil separator disc removes the oil separated on the liquid surface while the cleaning machine is off. The oil separator extends the service life of the washing fluid and ensures good cleaning results.

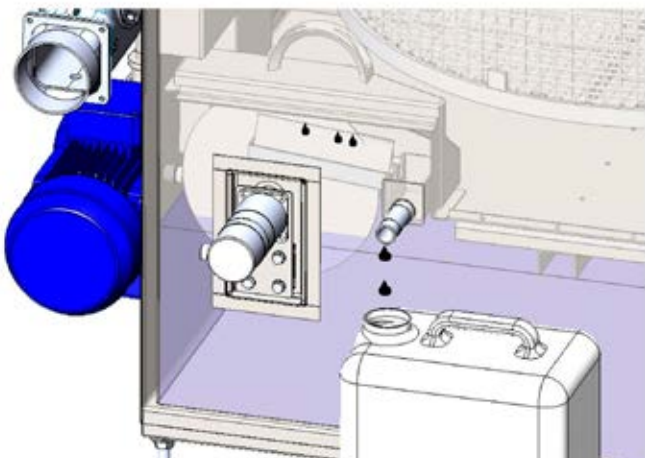

Automatic refilling AR-1

Automatic water refilling maintains the level of the fluid in the tank on a desired level.

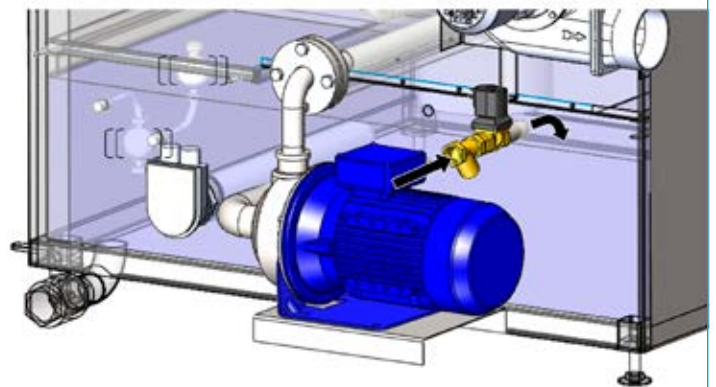

Sale & Service



PERS

INDUSTRIVEJ 12-16
7120 VEJLE Ø
75 82 66 33